



GAC CATERPILLAR ENGINE SOLUTIONS



GOVERNORS AMERICA CORP.

Agawam MA USA

(413)233-1888

<https://www.governors-america.com>

IN THIS BOOK

| | |
|---|-----------|
| CATERPILLAR C2.2 DIESEL ENGINE | 3 |
| Water Pump Drive and Power Generation | 3 |
| CATERPILLAR C0.5 DIESEL ENGINE | 4 |
| Power Generation for Battery Top Off | 4 |
| CATERPILLAR 3516 69L | 5 |
| Tugboat Propulsion | 5 |
| CATERPILLAR 3054 GEN SET ENGINE | 6 |
| Generator Set | 6 |
| CATERPILLAR 3304 and 3306 DIESEL ENGINES | 7 |
| Generator Set | 7 |
| CATERPILLAR 403D and C1.7 | 8 |
| Industrial Diesel Engine | 8 |
| CATERPILLAR G3406 14.6L NATURAL GAS | 9 |
| Industrial | 9 |
| CATERPILLAR 3406 DIESEL ENGINE | 10 |
| Industrial Generator | 10 |
| CATERPILLAR 3408 18 L NATURAL GAS | 11 |
| Industrial Generator | 11 |
| CATERPILLAR 3408 GOVERNOR REPLACEMENT | 12 |
| Fishing Vessel | 12 |
| CATERPILLAR 3412 ENGINE | 13 |
| Power Generation | 13 |
| CATERPILLAR DPA-DPD DELPHI DPG PUMP | 14 |
| Industrial Pump Replacement | 14 |
| CATERPILLAR DPA-DPD – DP210 ROTARY EXTERNAL PUMP REPLACEMENT | 15 |
| Off-Highway Pump Replacement | 15 |

CATERPILLAR C2.2 DIESEL ENGINE

Water Pump Drive and Power Generation

The ALR190 Series actuator and EEG6550 Speed Controller adds a complete electronic Governing System for a Caterpillar C2.2 engine. The EEG6550 digital governor was selected for having the most applicable combination of features. The speed ramping control significantly reduces visible exhaust smoke as the engine is accelerated under load.

The EEG6550 uses GAC's light force PID which scales the range of adjustment in support of the small, low current, ALR190 actuator, providing the best resolution for ease of tuning these governor response parameters.

- Caterpillar C2.2 Engine Idle to 3200 rpm
- 2.2L, 41.6 – 66.1 BHP
- Indirect fuel injection, PF Pump

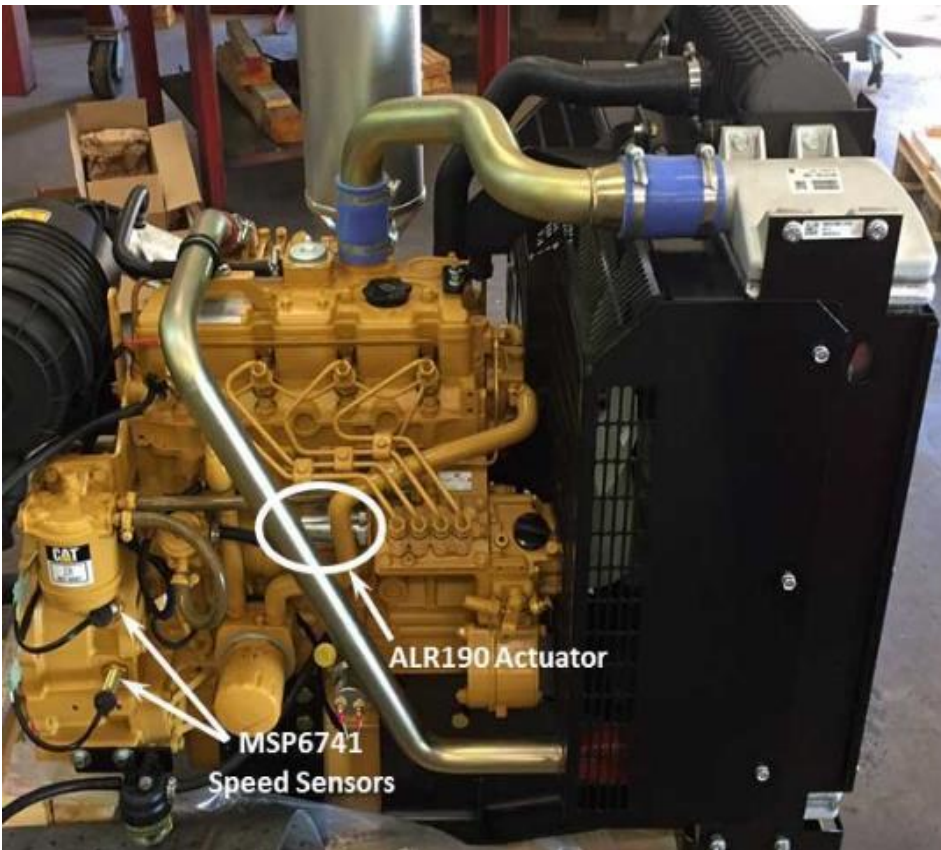

ALR190-P04



EEG6550



NOTE: All components are sold separately.

| COMPONENT | PART NUMBER | DESCRIPTION |
|------------------|----------------------------|--|
| Speed Controller | EEG6550 | EEG6550 Enhanced Electronic Governor, Multi-V DC, Simple user display, No PC required, Rated, idle, and variable speed |
| Actuator | ALR190-P04 | Linear Actuator, Supports Perkins 404D-15, 404D-22, and Caterpillar C2.2T, C3.4 |

CATERPILLAR C0.5 DIESEL ENGINE

Power Generation for Battery Top Off

The HPE Mining Series is a 4kw 48V DC generator used for precision lithium battery charging. “We convert the mechanical control of the engine to electronic utilizing the EEG7000 controller and a custom-built actuator to manage the speed of the engine which includes a warm up phase before load is applied then to main RPM, which controls voltage to charge the batteries. We maintain voltage to 0.1 volts which is very precise.”



EEG7000



Caterpillar C0.5
 11-13.7 HP
 U.S. EPA Tier 4 Final, EU Stage V
 Indirect Fuel Injection
 Naturally Aspirated

NOTE: All components are sold separately.

| COMPONENT | PART NUMBER | DESCRIPTION |
|------------------|-------------------------|--|
| Speed Controller | EEG7000 | EEG6550 Enhanced Electronic Governor, Multi-V DC, Simple user display, No PC required, Rated, idle, and variable speed |

CATERPILLAR 3516 69L

Tugboat Propulsion

A tugboat in Iceland needed to replace the main propulsion control system for its 2 Caterpillar 3516, 69L V16 engines. The output of both engines needed to be balanced, connected to a single drive train, and controlled with a single potentiometer.

The solution was to install two GAC ACB2001 actuators and two ESD5330 controllers connected with a harness designed for the application with built in potentiometers to adjust and balance the engines individually and a single potentiometer to control the speed of both engines at once.

All sea trials were successfully completed after the GAC Control system was installed. The tugboat returned to service, continuing to perform without incident. The Captain reported the fastest cruising speed ever.



ESD5330 (2)

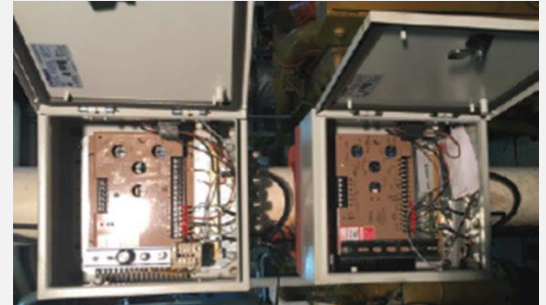

ACB2001 (2)

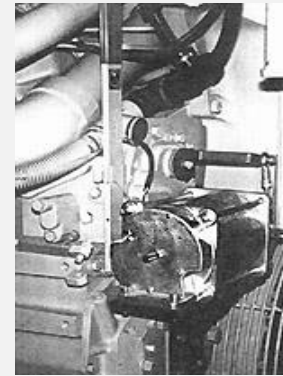

Wiring Diagram

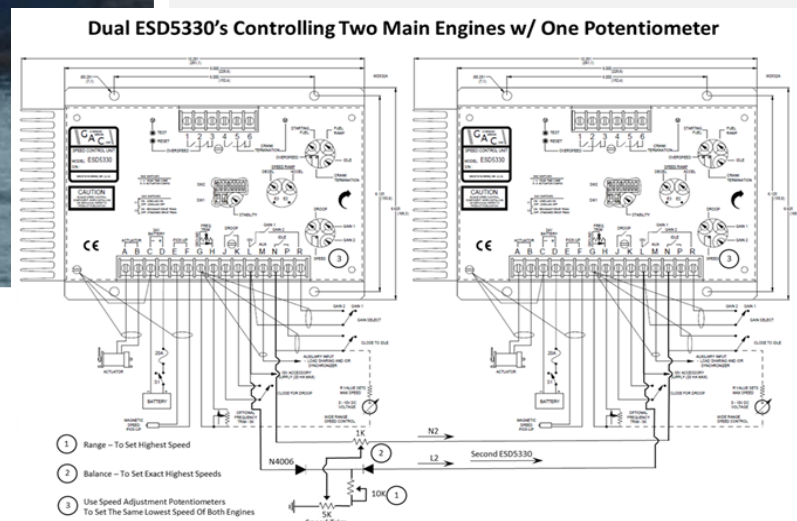

NOTE: All components sold separately.

| COMPONENT | PART NUMBER | DESCRIPTION |
|------------------|-------------------------|--|
| Actuator | ACB2001 | 24 V DC, Heavy duty, w/ lever, Terminal strip, Rapid response to transient conditions, Multiple mounting positions, Uni-directional CW/CCW, Internal return spring |
| Speed Controller | ESD5330 | 24 V DC, Two-element speed switch, |

CATERPILLAR 3054 GEN SET ENGINE

Generator Set

GAC Actuator ADC100–12/24 is designed to be installed as a replacement to an existing pump’s governor cover and act directly on the existing mechanical governor linkage arm.

This actuator works best with one of the GAC [light force](#) speed controllers. The customer selected the ECC328 Speed Controller which regulates and maintains the gen-set’s electrical frequency, and does not require a magnetic speed sensor.



ECC328



ADC100



NOTE: All components are sold separately.

| COMPONENT | PART NUMBER | DESCRIPTION |
|------------------|------------------------|--|
| Speed Controller | ECC328 | Gen-Set Frequency Controller, Light-Force (Low-Current Optimized PID) |
| Actuator | ADC100 | 100 Series Stanadyne Pump Mounted Actuator, Mounts directly to Stanadyne D Series pump |

CATERPILLAR 3304 and 3306 DIESEL ENGINES

Generator Set

This 500KW generator required a new governor. Depending on the engines fuel pump, a Caterpillar original or another governor, the ADD225GSC can replace either. The only difference is the installation steps.

The 225 Series actuator is installed on a solid bracket near the mechanical governor and linked to the stop lever. The throttle lever must be blocked in a forward position, resulting in a speed that is 200 - 300 RPM above the nominal operating speed.



ADD225GSC-24



ESD5500E



NOTE: All components are sold separately.

| COMPONENT | PART NUMBER | DESCRIPTION |
|------------------|---------------------------|-----------------------------------|
| Actuator | ADD225GSC | ADD225GSC-24 w/ Packard Connector |
| Speed Controller | ESD5500E | Variable Speed, Droop Governor |

CATERPILLAR 403D and C1.7

Industrial Diesel Engine

The ALR190 Series actuator easily replaces the electronic fuel stop solenoid in a Perkins or Caterpillar 403D and CATC1.7 engine.

The EEG6550 digital governor uses GAC's light force PID which scales the range of adjustment in support of the small, low current, ALR190 actuator, making it easier to fine tune response parameters.



ALR190-P403-12 / 24



EEG6550



NOTE: All components are sold separately.

| COMPONENT | PART NUMBER | DESCRIPTION |
|------------------|-----------------------------|--|
| Speed Controller | EEG6550 | EEG6550 Enhanced Electronic Governor, Multi-V DC, Simple user display, No PC required, Rated, idle, and variable speed |
| Actuator | ALR190-P403 | Linear Actuator, Supports Perkins 403D-15, 403D-15T, and Caterpillar C1.7 |

CATERPILLAR G3406 14.6L NATURAL GAS

Industrial

A GAC distributor in Alberta Canada upgraded a 14.64L, 6 cylinder Caterpillar G3406 natural gas engine to a GAC control system using an ATB652T2N-24 with an ESD5526 speed controller and an EAM121 as an interface. The GAC solution provided easy installation and superior performance.

The ESD5526E, with its anti-windup feature, is specifically designed for gaseous fueled engine control.



ESD5526E



EAM121



ATB652T2N-24



NOTE: All components sold separately.

| COMPONENT | PART NUMBER | DESCRIPTION |
|------------------|------------------------------|--|
| Actuator | ATB652T2N-24 | Integral Throttle Body Electric Actuator controls air or air/fuel mixture to a gaseous-fueled engine |
| Speed Controller | ESD5526E | Speed control unit is a closed loop control, with low current optimized PID |
| Interface Module | EAM121 | Interface module designed to communicate between ± 3 V DC output to nominal 5.0 V. |

CATERPILLAR 3406 DIESEL ENGINE

Industrial Generator

A complete electronic governor is installed on an existing Caterpillar engine without removing the fuel pump. The KT230 provides the necessary bracket and hardware to install the GAC 225 Series actuator.

The ESD5111, ESD5550E, or EEG6500 speed control units provide precise control adjustments. Complete [instructions are available on the GAC website.](#)



ADC225GS-24



ESD5111, ESD5500E, or EEG6500



Installation Kit KT230



NOTE: All components are sold separately.

| COMPONENT | PART NUMBER | DESCRIPTION |
|-------------------|---|--|
| Speed Controllers | ESD5111 , ESD5500E , or EEG6500 | Isochronous, Variable Speed, Droop Governor |
| Actuator | ADC225GS-24 | Electric Universal Actuator with Lesser Rate Return Spring |
| Other Items | KT230 | Installation Kit |
| | MSP6720 | Mag Pickup |
| | TP501 | 5K Potentiometer |

CATERPILLAR 3408 18 L NATURAL GAS

Industrial Generator

This industrial generator application uses the GAC Ignition Control Module (ICM) paired with a ACB2001 actuator and an ESD5330 Speed controller. The ignition system operates in wasted spark mode with crankshaft triggering, CAT 3408, 18 L, V-8, with 136 flywheel teeth.

While the ICM tends to the spark, the ESD5330 ensures smooth, responsive governing control.



ICM200-4



ESD5330



ACB2001



NOTE: All components are sold separately.

| COMPONENT | PART NUMBER | DESCRIPTION |
|-------------------|--------------------------|--|
| Actuator | ACB2001 | Rotary output, 24 V, linear torque proportional electric servo torque to 16.3 Nm |
| Ignition Control | ICM200-4 | Charges a high-energy inductive ignition coil using technology with fixed and variable timing modes and in-field timing trim/offset |
| Speed Controllers | ESD5330 | Speed control unit designed to precisely control engine speed and provide fast precise response to transient engine loads using the ACB2001. |

CATERPILLAR 3408 GOVERNOR REPLACEMENT

Fishing Vessel

A fishing vessel needed a cost-effective replacement to their aging Woodward PSG but a one-for-one replacement was expensive and installation time consuming. They chose GAC's external mount ADB225 and the ESD2244-24, to save both downtime and money.



ADB225



ESD2244-24



NOTE: All components are sold separately.

| COMPONENT | PART NUMBER | DESCRIPTION |
|------------------|-------------------------|--|
| Actuator | ADB225 | Electric Universal Actuator, Rotary-output, linear-torque, 2.2 lbf-ft [3.0 N·m] torque, 25° rotation |
| Speed Controller | ESD2244 | 24 V DC Light-Force (Low-Current Optimized PID), Isochronous operation, Precise speed control, Adjustable PID functions, 8:1 speed range control |
| Other | MSP6723C | Magnetic Speed Pickup: |

CATERPILLAR 3412 ENGINE

Power Generation

The ADC225GS is a perfect solution to replacing a PSG governor assembly. The pump rack control lever is used to create a non-invasive installation. The mechanical Caterpillar governor is not replaced, simply provided with better control.

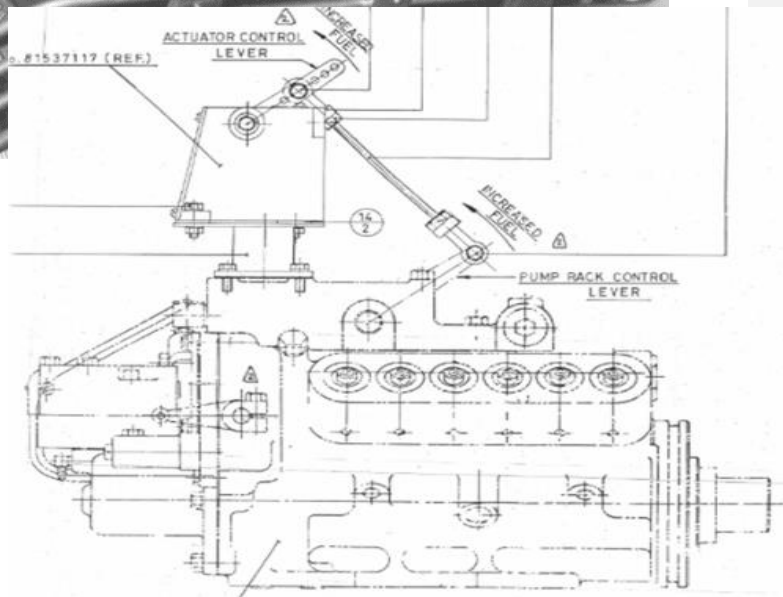
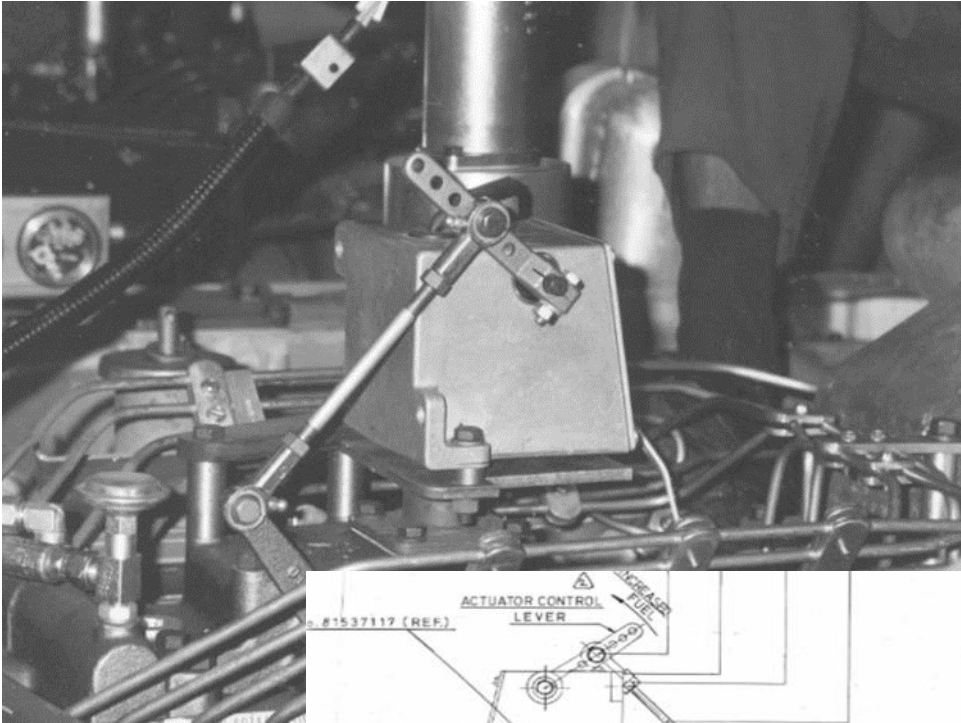

ADC225GS-24



ESD5111, ESD5500E, or EEG6500



NOTE: All components are sold separately.

| COMPONENT | PART NUMBER | DESCRIPTION |
|-------------------|---|--|
| Speed Controllers | ESD5111 , ESD5500E , Or EEG6500 | Digital Controllers w/ start fuel and speed ramping adjustments, Enhanced Electronic Controller, Built-In Display, Fast setup 2 Fixed (Rated, Idle) and Variable Speed; Selectable Isochronous, Droop, & Variable Governing |
| Actuator | ADC225GS-24 | Electric Universal Actuator with Lesser Rate Return Spring |

CATERPILLAR DPA-DPD DELPHI DPG PUMP

Industrial Pump Replacement

The [103](#) Series Integral Actuator is designed to mount directly to the Delphi DPA/DPD (fixed speed-versions). No external linkage or brackets are required to install this actuator. By internally moving the fuel metering valve to the no fuel position, when de-energized, the 103 Series electric actuator provides the function of fuel shutoff solenoid.

Installing the 103 Series actuator does not defeat the engine's mechanical governor operation. During installation the mechanical governor is set to a higher speed than the electric governor's operating speed. This configuration uses the mechanical governor as a speed limiter. The electromechanical design used in the 103 Series is field proven and provides a proportional actuator movement based on the actuator coil current.

ADD103

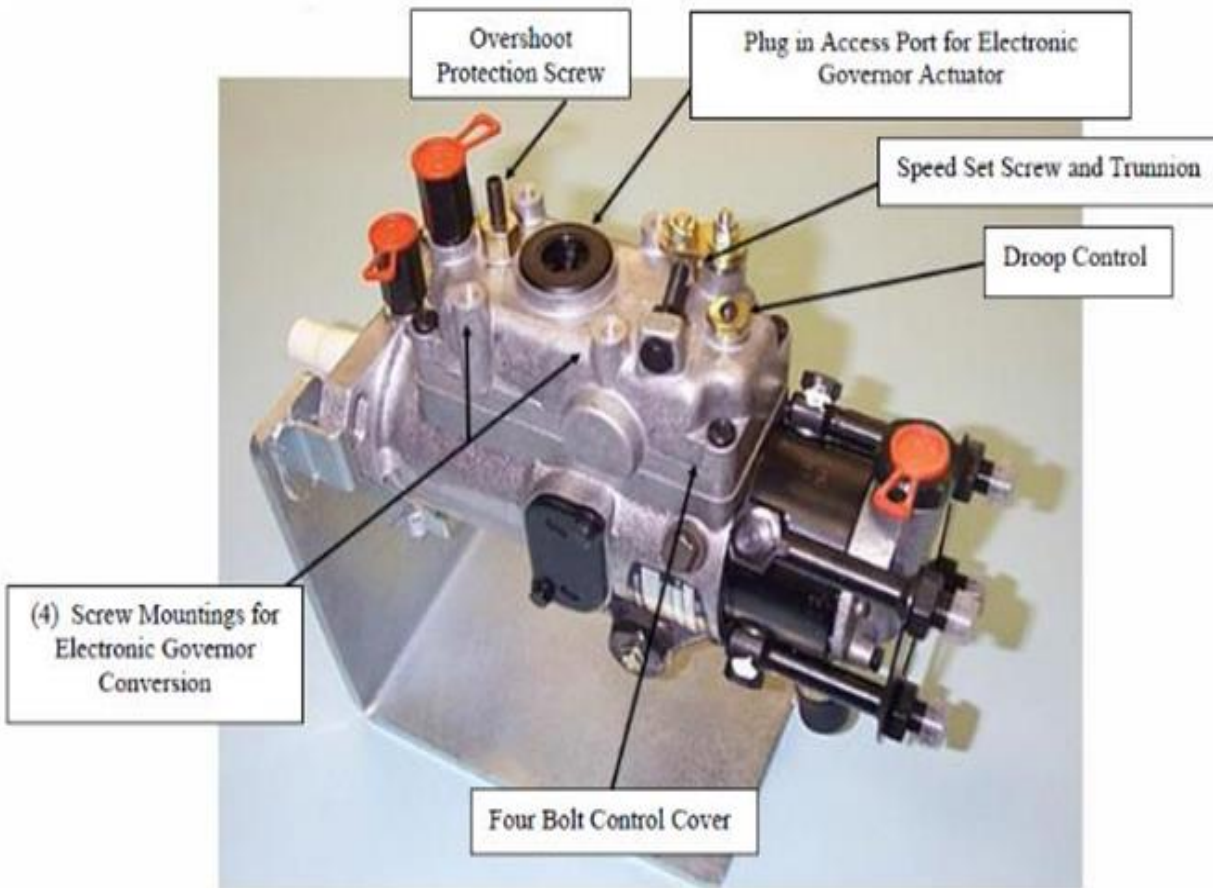

[INSTALLATION INSTRUCTIONS ARE AVAILABLE ON THE GAC WEBSITE.](#)

| COMPONENT | PART NUMBER | DESCRIPTION |
|-----------|------------------------|---|
| Actuators | ADD103 | Pump Mounted Actuator, 12/24 V DC, Mounts directly to Delphi DPG/DP210 pump |

CATERPILLAR DPA-DPD – DP210 ROTARY EXTERNAL PUMP REPLACEMENT

Off-Highway Pump Replacement

Perkins, Caterpillar and other 3-, 4-, and 6-cylinder engines in off-highway applications with the DP210, DPA, or DPD pumps are mechanically governed.

They can be replaced with the GAC ALN050 or 120 Series universal actuator by mounting them to the pump's throttle lever.



ALN050



ESD2402, ESD5120, or EEG6500



NOTE: All components are sold separately.

| COMPONENT | PART NUMBER | DESCRIPTION |
|-------------------|---|--|
| Actuator | ALN050 | Linear Push Actuator, 12 or 24 V DC, 13.0 lbf [6.0 kgf], 0.50 lbf-ft [0.68 J] Work, Male Push-On Terminals |
| Speed Controllers | ESD2402, ESD5120 , or EEG6500 | Isochronous, Variable Speed, Droop Governing, Adjustable Light-Force (Low-Current Optimized PID) |
| Other | MSP675 BK266 | Magnetic Speed Pickup: Mounting Kit |



SOLUTIONS THAT OUTLIVE THE LIFE OF THE ENGINE

GAC OFFERS PROVEN RESULTS

GAC provides cost-effective solutions that offer the greatest potential for improvements in both engine efficiency and emissions while providing many features.

Governors America Corp. (GAC) is a leading provider of innovative engine control products worldwide. As a veteran-owned and operated family business, our dedication and focus on our customers' needs has shaped GAC into a vertically integrated company with complete design, development and manufacturing capabilities.

Our mission is to provide trusted solutions for the innovative equipment that powers and builds our world. GAC's market-focused efforts provide precise electromechanical and electronic engine devices and speed control systems globally.