

# 275 Series Integrated Pump Mounted Electric Actuator

## 1 OVERVIEW

The 275 Series actuators are electromagnetic linear servo devices that control the fuel rack of in-line injection pumps with up to 16 cylinders. Installing the 275 Series actuator with a GAC analog or digital controller and an engine speed sensor provides a high performance, closed-loop engine speed control system.

These actuators have no sliding parts and are totally sealed. They provide outstanding reliability and require no maintenance. Camshaft bearing retainer kits, position feedback transducer, and heavy duty bearing retention options are also available.

- High Performance Fuel Control
- Maintenance-Free Operation
- Stop Lever for Manual Control
- Available With Feedback Sensor
- Control Up to 16 Cylinder Pumps
- Adjustable Maximum Fuel Limit
- Mounts Directly on Bosch 'P' and 'RP 21' Fuel Injection Pumps in place of a Mechanical Governor

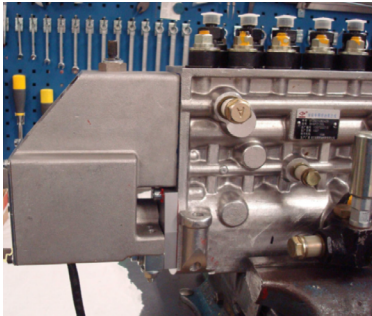

ACB275C



ACE275K



ACB275H



ACE275HD-24

## 2 SPECIFICATIONS

PERFORMANCE	
Force	13.2 lbf MAX [17.89 N·m]
Operating Stroke	0.79 in Nominal [20 mm]
POWER INPUT	
Operating Voltage	24 or Multi-V DC
Normal Operating Current	3 A @ 12 V DC 1.5 A @ 24 V DC
Maximum Current (Continuous)	9 A @ 12 V DC 4.5 A @ 24 V DC
PHYSICAL	
Dimensions	See <a href="#">Section 4, Actuator Dimensions</a>
Weight	12 lbf [5.4 kgf]
Mounting	See <a href="#">Section 5, Installation</a>

ENVIRONMENT	
Operating Temperature Range	-40 ° to 257 °F [-40 ° to +125 °C]
Relative Humidity	Up to 100 %
Vibration	HD Models: 31 g <sub>rms</sub> vertical, 17 g <sub>rms</sub> transversal 12 g <sub>rms</sub> longitudinal @ 20-2000 Hz  Other Models: 21 g peak @100-2000 Hz
Shock	20 G @ 11 ms
All Surface Finishes	Fungus Proof and Corrosion Resistant
RELIABILITY	
Testing Agency	CE, RoHs, BV, Lloyd's Register, DNV/GL

**ACTUATOR SELECTION CHART**

PRODUCT	SYSTEM VOLTAGE		CONNECTOR		FEATURES					NOTES
	24 V DC	Multi V DC	MIL	Packard	Heavy Duty Bearing Retention	Position Feedback Sensor	Oil Drain Fitting	Extended Travel	Stop Lever Included	
ACB275C										Designed for MTU. Sand cast housing and aluminum cover.
ACB275H										
ACE275H-24										
ACE275HD-24										
ACE275J-24										Includes compression style oil drain fitting for 10 mm diameter tube, for use on Deutz 1015 / 2015 with high crankcase pressure.
ACB275H-S1										Includes barbed oil drain plug fitting supporting M12 X 10 hose. Special Order.
ACE275K										

**CAMSHAFT BEARING RETAINER KITS**

INJECTION PUMP	KIT
Bosch MW Pumps	<a href="#">KT166</a>
Bosch P 3000 Pump	<a href="#">KT275</a>
Bosch P 7000 Pump	<a href="#">KT276</a>
Bosch RB RP21 Pump with RB Plate	KT278
Bosch RP21 Pump for Marine Applications	<a href="#">KT278-1</a>
MTU Bosch P 3000	KT3000-MT
MTU Bosch P 7000	<a href="#">KT7001-MT</a>

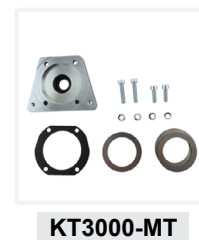
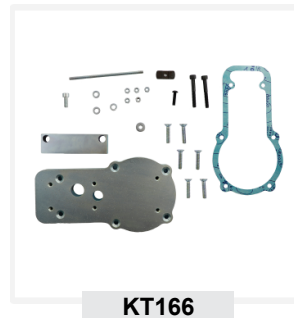

**CONNECTORS & HARNESES**

	ACTUATOR TYPE	CONNECTOR	DESCRIPTION
Connectors	ACB	EC1000	Military - Straight
	ACB	EC1010	Military -90°
	ACE	EC1300	Packard Mating Connector
	ACE	EC1310	Packard Replacement Connector
	ACE275K	EC1515	AB Position Sensor (Requires EC1300)
Harnesses	ACB	CH1203	Military - Straight 12 ft [3.6 m]
	ACB	CH1210	Military - 90° 12 ft [3.6 m]
	ACE275K	CH1515	AB Position Sensor 6 ft [1.8 m]



## 4 ACTUATOR DIMENSIONS

275 Series actuators dimensions are similar in core ways but differ with additional features including feedback sensors, connector types, heavy duty bearings, oil drain access, and mounting configurations. Installation and location of the physical unit will depend on your configuration.

### 275 SERIES CORE DIMENSIONS

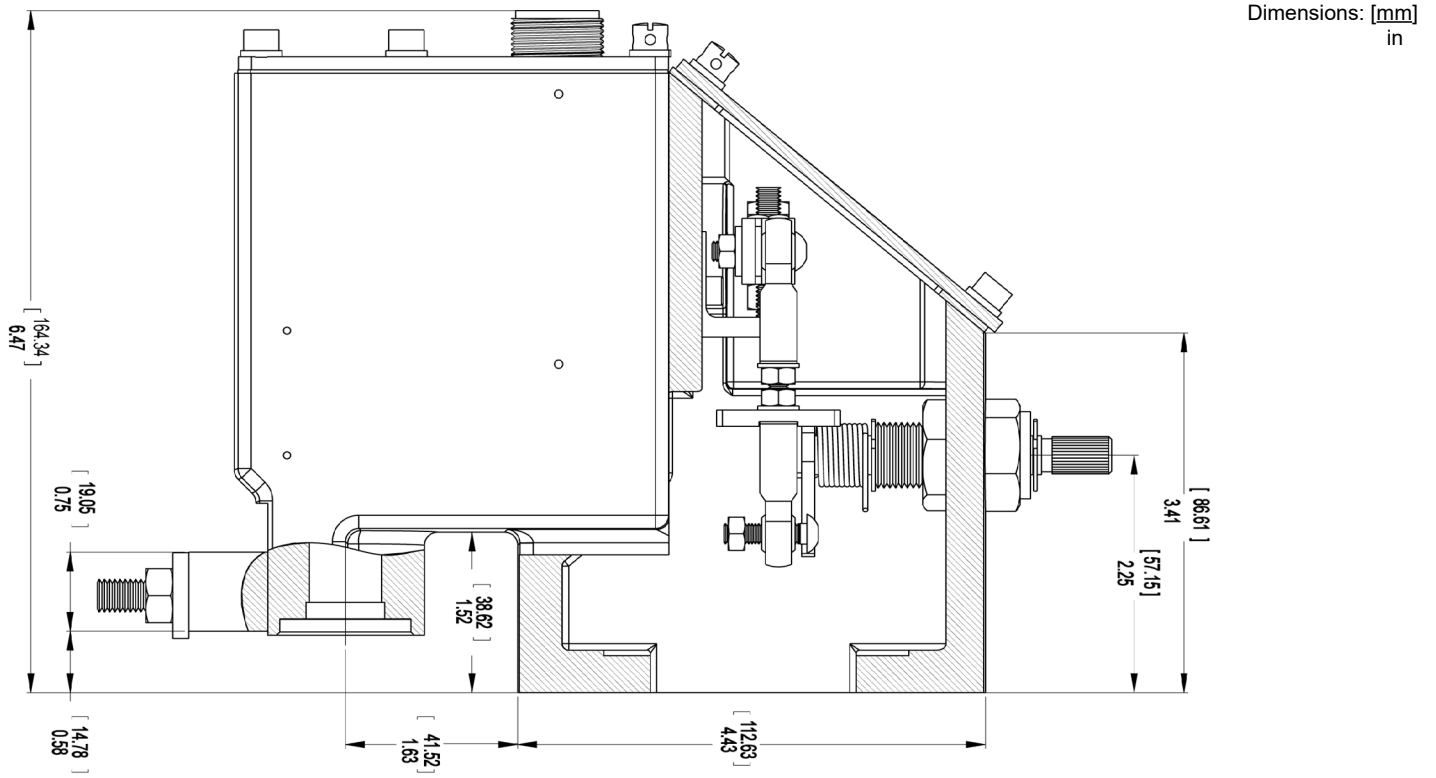

### 275 SERIES C SERIES ADDITIONAL DIMENSIONS

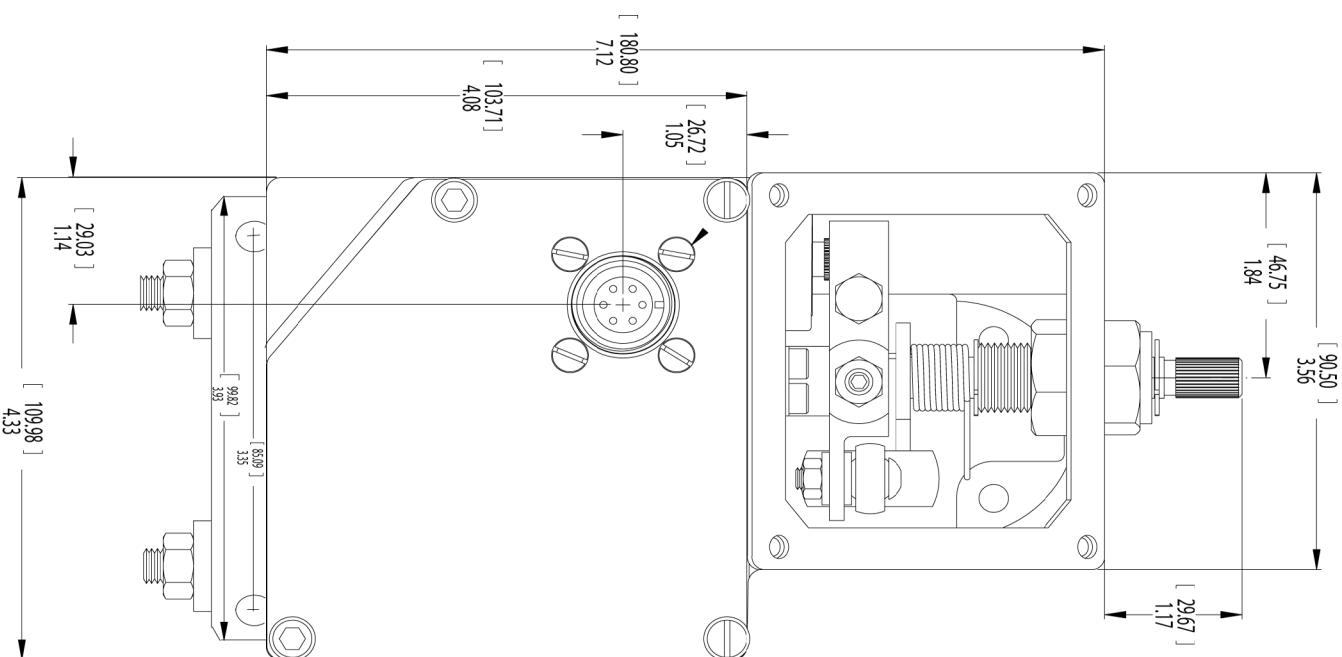

275 SERIES H SERIES MOUNTING DIMENSIONS

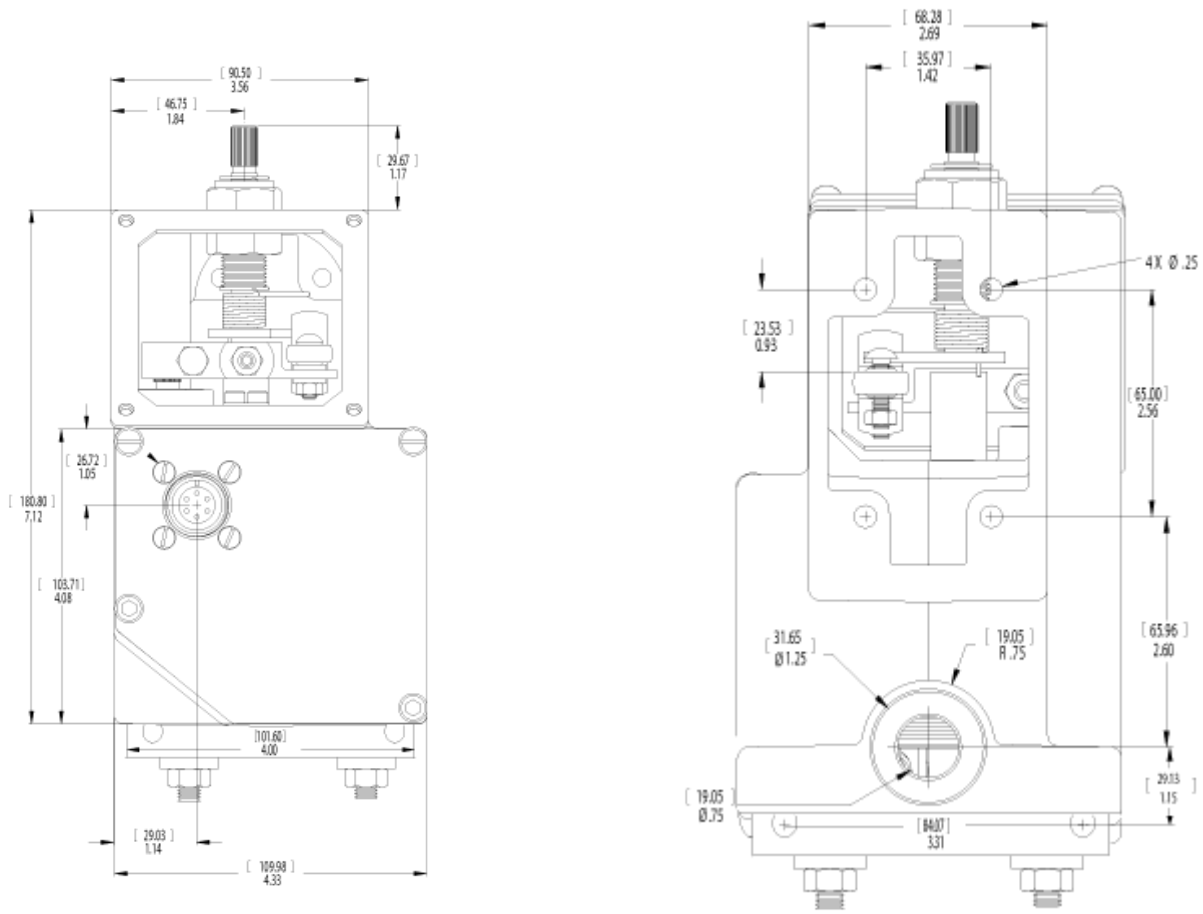

ACB275H-S1 - DRAIN PLUG LOCATION

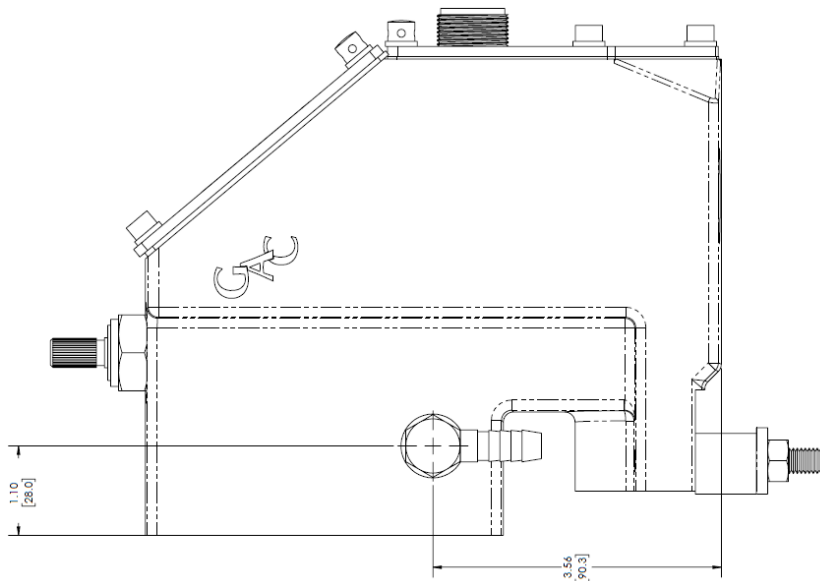

## 4 ACTUATOR DIMENSIONS (CONTINUED)

### 275 SERIES J SERIES ADDITIONAL DIMENSIONS

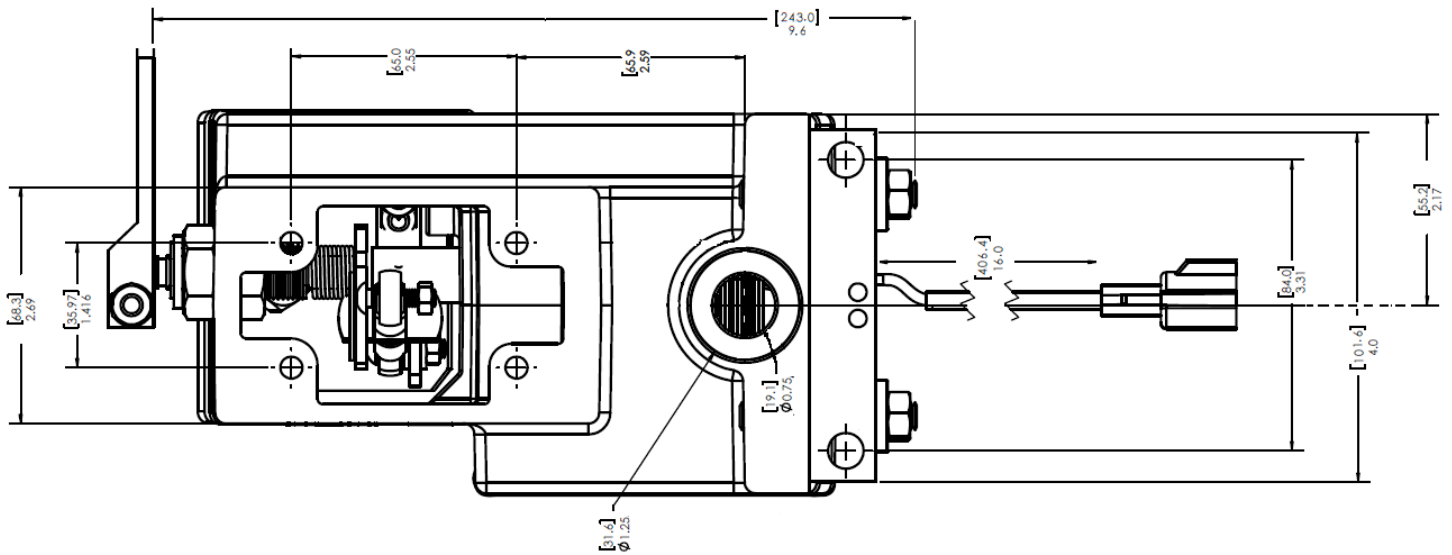

### 275 SERIES K SERIES ADDITIONAL DIMENSIONS

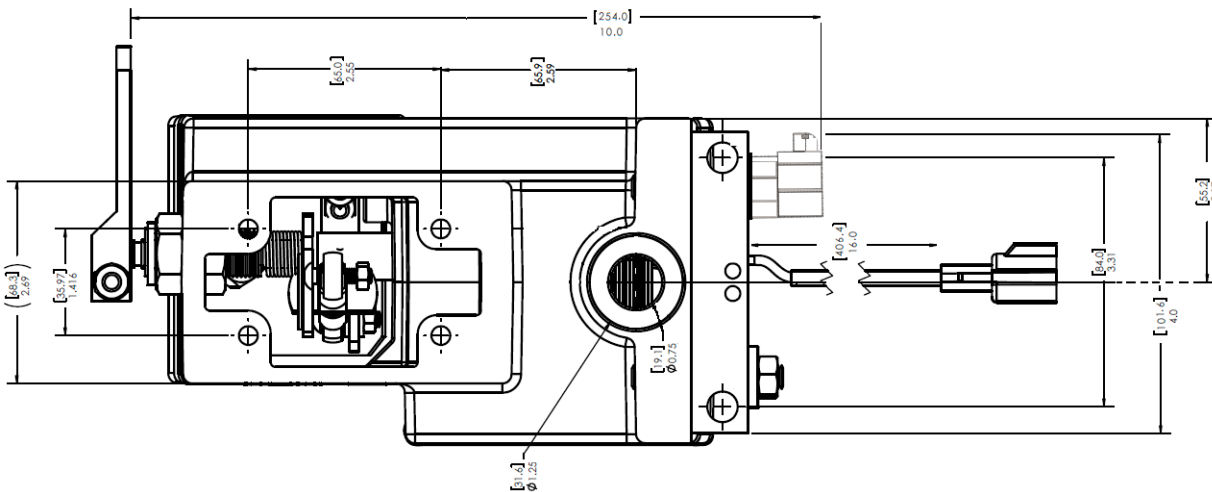

## 5 INSTALLATION



If the pump is equipped with a mechanical governor, it must be removed. GAC recommends that the modification be done by a qualified fuel injection shop. These installation steps are a generalized procedure.

The engine should be equipped with an independent shut down device to prevent overspeed which can cause equipment damage or personal injury.

### PREPARING THE FUEL INJECTION PUMP

1. Remove the rear housing of the mechanical governor and disconnect the governor assembly from the fuel rack.
2. Remove the flyweight assembly.
3. Remove the intermediate governor housing, this leaves only the rack and camshaft protruding from the housing.
4. As required, install the appropriate camshaft bearing retainer kit. This kit includes the correct shims to ensure that the retainer plate rests on the bearing and also prevents oil from leaking out around the camshaft. See Section 3 for a list of [installation kits](#) by pump type. Contact your GAC representative for installation instructions.
5. Located on the pump between the fuel rack and the camshaft, remove the oil hex plug to allow any oil leaking from the fuel rack, to drain back into the pump. The oil must be removed from the mechanical governor.

## 5 INSTALLATION (CONTINUED)

### INSTALLING THE ACTUATOR

1. Remove the four screws that fasten the top cover to the actuator and expose the linkage used to connect the actuator to the fuel rack.
2. Remove the screw that attaches the ball bearing rod end to the lever. Do not remove or loosen the lever from the actuator shaft.
3. The opposite end of the linkage must be attached to the top of the fuel rack with the screw and lock nut provided. Tighten the screw and nut securely to 4.0 – 4.5 N·m. The linkage is preset to a specific length and locked. Any adjustment of rack travel must be made using the slot on the actuator lever. If linkage length adjustment is needed, consult with GAC or its distributors first.
4. The gasket supplied in the actuator installation parts kit fits between the actuator and pump. Clean the mounting surfaces of the actuator and the pump on one side of the gasket to the actuator. A small amount of gasket sealant, such as RTV silicone, is recommended for the pump side of the gasket.
5. Loosen the two M8 hex nuts that hold the lower mounting bar to the actuator.
6. Place the actuator over the rack and linkage. Fit the lower part of the actuator onto the bearing retainer plate.
7. Attach the actuator to the pump with four M5 x 22 mm screws and washers through the upper mounting holes. Tighten these screws securely to 9 N·m so that the gasket is compressed evenly.
8. Push the lower mounting bar against the bearing retainer plate and tighten the two M6 nuts onto the studs that are in the pump to 10 N·m.
9. Tighten the two M8 nuts on the studs that hold the mounting bar onto the actuator to 18 to 20 N·m.
10. The linkage attached to the fuel rack must be free when moved from shut off to full fuel. Pull the linkage fully away from the pump.
11. Push the linkage 1 mm toward the pump and attach it to the slot in the actuator lever with the M5 screw, two flat washers and locking nut. Tighten to 4 N·m. The fuel rack should be 1 mm or less away from its internal physical stop. The zero fuel stop of the system will now be provided by the actuator instead of inside the fuel pump.
12. Manually move the actuator lever and linkage through its full range of motion. No binding should be noticed. The actuator operating lever & assembly must not contact the inside of the housing.
13. A maximum fuel stop adjustment is located on the actuator lever. The set screw and lock nut may be adjusted to limit the travel of the fuel rack.
14. Push the linkage to the full fuel position and operate the manual shut off to ensure that the shut off lever correctly contacts the stop plate and forces the linkage to zero fuel.
15. After the maximum fuel delivery has been adjusted on an engine or dynamometer, the top cover may be installed. Place the sealing screw in the lower left hand corner if required and lock-wire the two covers together to prevent tampering if available.

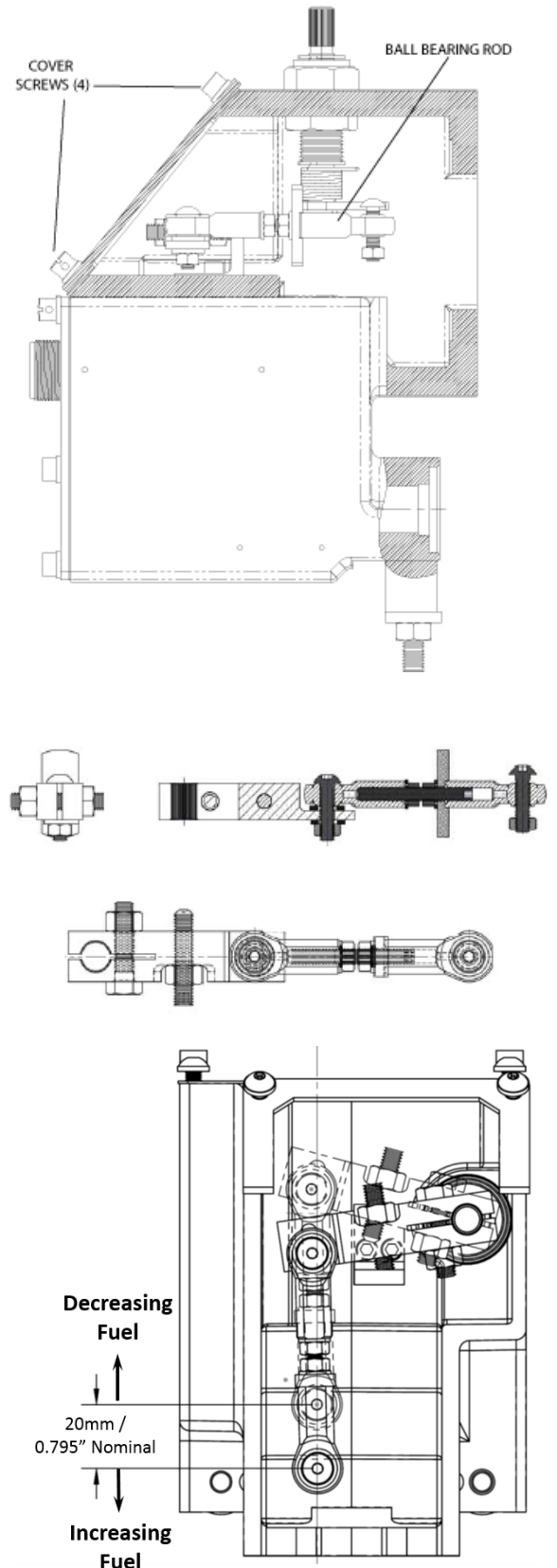

# 6

## WIRING

The EC1000 or EC1010 electrical connector that mates with the actuator must be pre-wired in a configuration to match the system voltage. Cable Harnesses CH1203, CH1215, & CH1515 are available from GAC. See Section 3, Actuator Selection Chart, [CONNECTORS & HARNESSSES table](#) for more details.

Fabricate a cable harness to connect the speed control unit to the actuator using the following gauge wire:

CABLE HARNESS	
16 Gauge [1.5 mm <sup>2</sup> ]	12 V DC
16 Gauge [1.5 mm <sup>2</sup> ]	24 V DC

**NOTE** Use larger gauge wire for cable lengths greater than 12 ft [4 m].

### 12 V DC - ACB275H ONLY

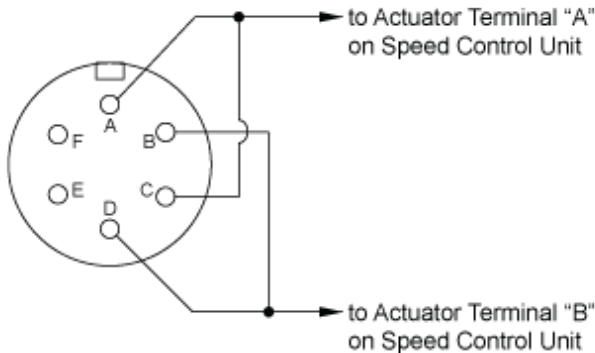

### 24 V DC - ALL MIL

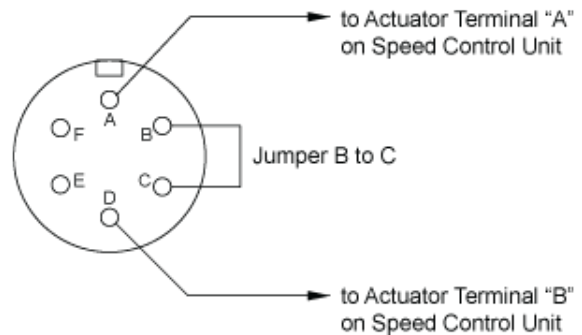

### MILITARY CONNECTOR

**NOTE** For 32 V operation, wire the connector as shown for 24 V operation and add a 1.5 Ω, 25 V resistor in series with pin A of the actuator connector and the corresponding output terminal of the speed control unit.

### ADB275F / ACB275F WIRING ONLY

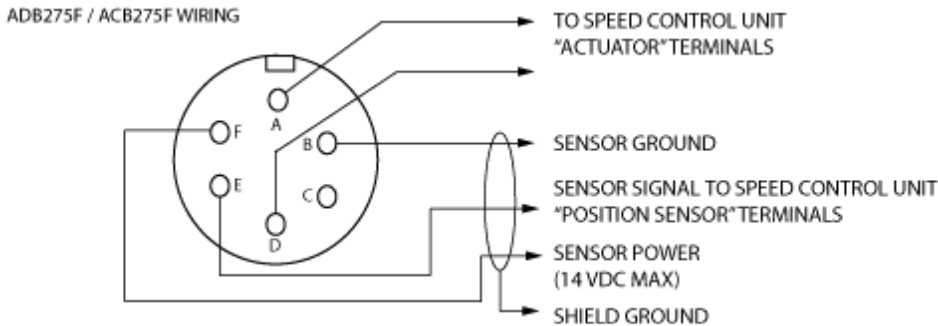

### FEEDBACK SENSOR

The ACB275F and ACE275K actuators include a rack position sensor. A GAC speed control unit that includes fuel management electronics is required to interface with this sensor. See your speed controller installation guide for additional wiring information.

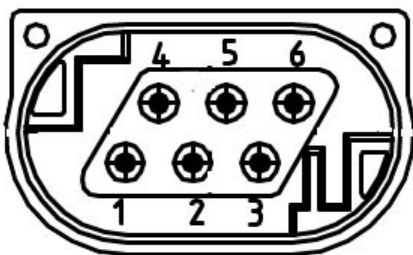

HARNESS	
PIN	SIGNAL
1	+5 V INPUT
2	GND
4	OUT (0.5 - 4.5 V)

# 7

## TROUBLESHOOTING



The engine should be equipped with an independent shut down device to prevent overspeed which can cause equipment damage or personal injury.

If the governor system fails to operate, make the following tests at the actuator mounted connector while moving the actuator through its stroke.

### TROUBLESHOOTING TEST

1. Energize the actuator to full fuel following the steps in your speed control units installation manual.
2. Manually move the actuator through its range using the stop lever. No binding or sticking should occur.
3. If the actuator passes three tests, the problem is elsewhere in the system. See the troubleshooting section of your speed control unit's installation manual.

### MILITARY CONNECTOR

MEASURING THE RESISTANCE	
TERMINALS	RESISTANCE
A to B	(12V) 2.5 Ω
C to D	(12V) 2.5 Ω
A to C	Infinity
A to Housing	Infinity
C to Housing	Infinity
E to F	Infinity

### PACKARD CONNECTOR

MEASURING THE RESISTANCE	
TERMINALS	RESISTANCE
A to B (24V)	4.7 Ω
A to Housing	Infinity
B to Housing	Infinity

### 275 SERIES ACTUATOR FORCE VERSUS RACK TRAVEL

