

Cummins QST30 GAC Conversion Installation Instructions

1 INTRODUCTION

The 30.5L V12 Cummins QST30 engine comes from the factory with a Cummins PCC controller and a Bosch EDC actuator mounted on each injection pump. The engine is used in a variety of applications with a rated power range of 760 to 1500 HP (567 to 1119 kW) but its control system is not easily accessible, making aftermarket adjustments and service difficult. GAC has created an alternative cost-effective solution using Governors America Corp. Dual Driver Module (DDM101) and governor control system is easy to install and simple to calibrate.

The GAC solution removes the factory integrated system and replaces it with a system that allows direct access for tuning. The solution involves installing the following:

- ADD175F actuators to each pump with a simple adapter kit to allow easy access to controls.
- K-Type thermocouples in the exhaust stream of each bank to aid in equal fuel distribution
- DDM101 which uses input from the two thermocouples and two position sensors to balance and maintain an equal output from both banks of the engine while being controlled by a single governor, the ESD5111 or ESD5221 (with overspeed).



- Read this entire installation manual before you begin.
- Follow all local safety instructions and rules.
- The engine should be equipped with an independent shut down device to prevent overspeed, which can cause equipment damage or personal injury.

NOTE

The GAC parts listed are NOT compatible with the Cummins PCC controller or the Bosch injection pump mounted actuators. This finished system acts as a standalone complete dual pump governor system that does not require interaction with the Cummins controller.

MATERIALS AND TOOLS

The following parts are needed for this solution.

Description	GAC Part Number	Qty
Actuator	ADD175F	2
Driver Module	DDM101	1
Feedback Sensor Mating Harness	CH1243	2
Actuator Harness	CH1215	2
Magnetic Speed Pickup 5/8 - 18	MSP678	--
Magnetic Speed Pickup Harness	CH1204	1
Speed Controller	ESD5111 (or ESD5221 w/overspeed)	1
Bosch EDC Governor Adapter Kit	KT197	2
K-Type Thermocouple (Kit includes EGT Bung)	STE101 (HW11-030)	2

INSTALLING MAGNETIC PICKUPS

Ensure magnetic pickups are installed, or install them as needed before starting this installation. See the [GAC Magnetic Pickup](#) information for details and talk to your GAC representative.

1. Ensure the engine is not running and the ignition is in the OFF position.
2. If no mounting location is pre-drilled, drill and tap a threaded hole in the flywheel housing perpendicular to the center line of the crankshaft and centered over the ring gear teeth. Spot face the hole to provide a flat surface on which to anchor the locknut.
3. Insert the magnetic speed pickup into the hole and turn it until the magnetic speed pickup makes contact with the crown of a gear tooth.
4. Back out the magnetic pickup by turning it counter clockwise, about 1/4 turn.
5. The gap between the pickup and gear should be between 0.025 in (0.64 mm) and 0.035 in (0.89 mm) Wire leads should be twisted for their entire length from the magnetic speed sensor to the control unit. Shielding is required if external interference is present or the leads are longer than 10 ft (3 m).
6. Use an AC voltage meter to verify proper magnetic pickup installation. During cranking, sensor output should be 1.5 V AC minimum.

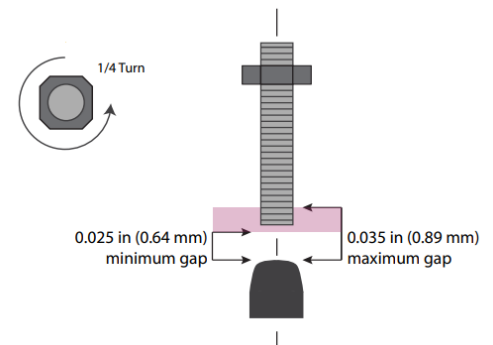

2 REMOVE FACTORY ACTUATOR

At each pump on the 30.5L – V12 Cummins QST30 engine, complete the following. GAC highly recommends you complete installing this solution on one pump before starting the second pump.

REMOVE REAR OF GOVERNOR HOUSING

1. Remove the rear half of the governor housing, Figure 1. Follow Cummins instructions to remove the existing Governor housing and disconnect the governor linkage from the fuel rack.

NOTE The mechanical governor will release oil during removal.

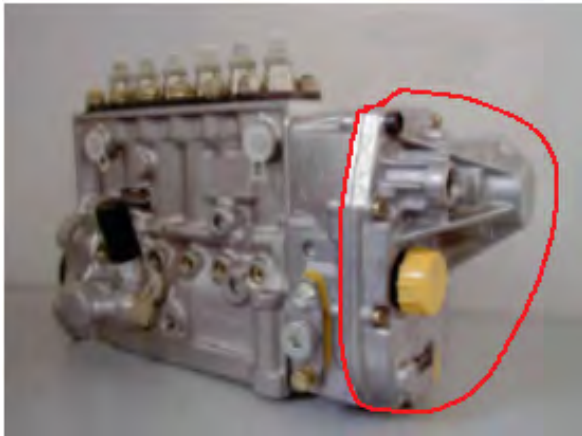

FIGURE 1 REAR OF GOVERNOR



FIGURE 2 REAR GOVERNOR HOUSING REMOVED

3 ADD RACK EXTENSION AND ADAPTER PLATE

1. Clean any grease or other materials from the surface of the housing (Figure 2).
2. Using the KT197 kit, dry fit the gasket, Figure 3 (1), to the existing holes on the governor housing. Ensure the holes align with the gasket.
3. Insert the rack link extension into the fuel rack and line up extension mounting holes with the mounting holes in the fuel rack.
4. Use the included M5 spring washers and cap screws, Figure 3 (5), (6), to secure the extension to the fuel rack.
5. Torque to 27-33 in-lbs (3-4 N·m). Make sure the rack moves freely in its bore through its full stop-to-stop travel.
6. Remove the adhesive tape backing from the gasket, Figure 3 (1), in small sections as you attach the gasket to the housing. Do not remove the tape all at one time.
7. Install the adapter plate, Figure 3 (3), on the front of the housing. Ensure the plate is seated on the gasket.
8. Hand tighten the 8 flathead hex screws, Figure 3 (4), on the plate. Alternating at opposite sides on the plate, torque screws to 95-105 in-lbs (10.5-12 N·m).

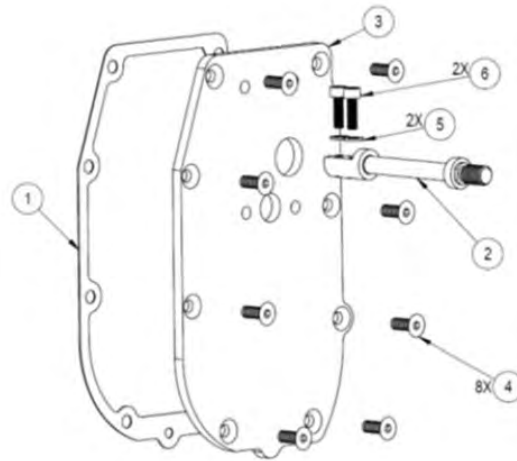

FIGURE 3 ADAPTER PLATE



FIGURE 4 RACK LINE EXTENSION

3 ADD RACK EXTENSION AND ADAPTER PLATE (CONTINUED)

9. Slide spring seat, Figure 5 (6), over rack extension (1) and seat against adapter plate.
10. Place the fuel rack return spring (2) over the fuel rack extension (1) against the spring seat (6).
11. Place the spring retainer (3) and shut-off plate (4) with the M10 castle nut (5) over the threads on the rack extension.
12. Thread the castle nut onto the link extension and torque to 60-70 in-lbs (6-8N·m).

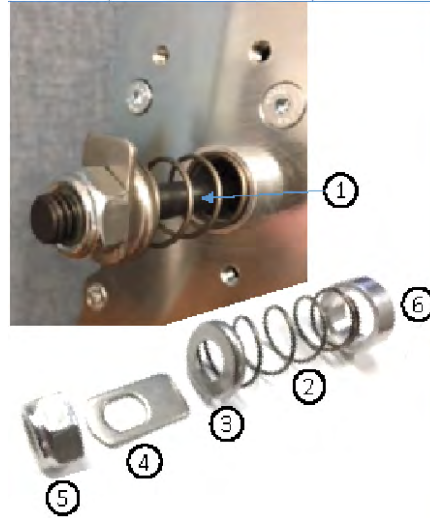

FIGURE 5 RACK EXTENSION FUEL SPRING RETURN



FIGURE 6 ADAPTER PLATE and RACK EXTENSION INSTALLED

1. Remove the upper actuator cover, Figure 7 (1), and O-ring seal (2). Save all hardware.
2. Clean the actuator to pump adapter mounting surface so it is free of any debris.
3. Insert two M6 X 16 mm long screws and spring washers, Figure 7 (15), through the lower mounting holes inside the upper actuator cavity.
4. Align the gasket, Figure 7 (5), and install it over the two screws and carefully slip the actuator over the fuel rack assembly until the two lower screws just start to meet the fuel pump mounting holes.

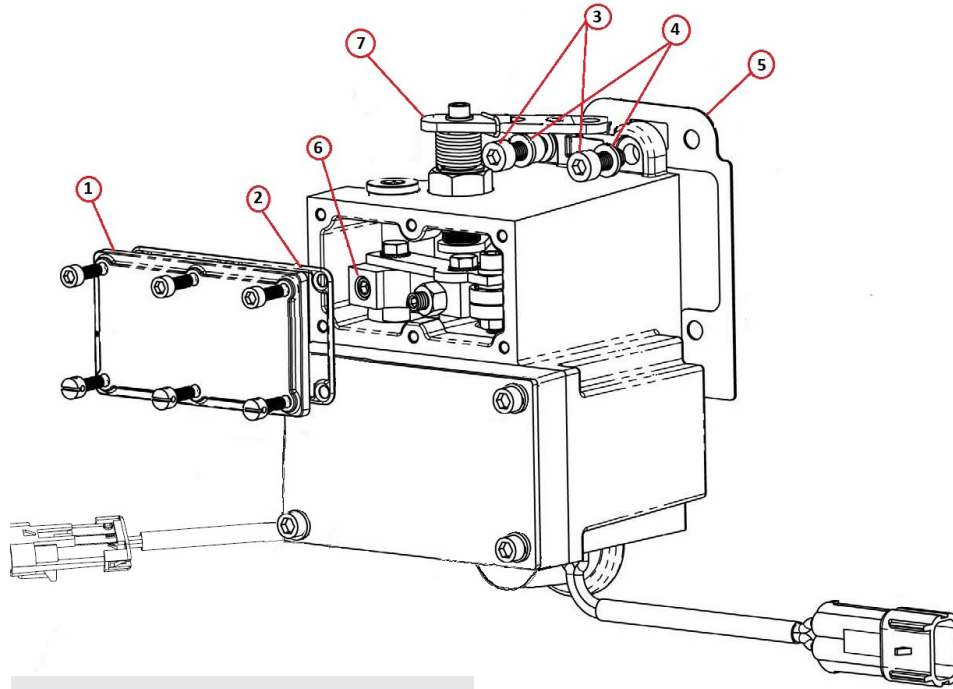

FIGURE 7 ACTUATOR MOUNTING

5. Insert a ball end hex wrench through the access point located on the operating lever, Figure 7 (6), and tighten the left lower mounting screw (15) a few turns.
6. Pull the operating lever outward and slide the ball end hex wrench into the space between the operating lever and the access point in the housing of the actuator and tighten the right lower mounting screw.
7. Once these two screws are fully engaged (do not tighten at this time) into the pump housing, insert two additional M6 X 16 mm long screws, Figure 7 (3), and spring washers (4) into the top two mounting holes of the actuator and thread into the pump housing.
9. Torque all four mounting screws to 5-6 N·m (44-53 in-lb).
10. Verify the fuel rack assembly moves in and out freely inside the upper cavity of the actuator by moving the fuel shutoff lever, Figure 7 (7).

4 INSTALLING ADD175 ACTUATORS (CONTINUED)

11. Carefully loosen screws, Figure 8 (11), and (18) over the slotted portion of the adjustment plate so the operating lever bearing assembly (17) can be moved away from the fuel rack connection link.
12. Ensure the fuel rack is as far out of the pump as possible.
13. Rotate the operating lever (13) out from the actuator until it stops. The armature of the actuator will be in contact with the lower cover. Hold in this position.
14. Rotate the adjustment plate and lever bearing assembly, (17), in towards the fuel rack so contact between the bearing and rack connection link is made. Continue to push in an additional 1 to 2 mm.

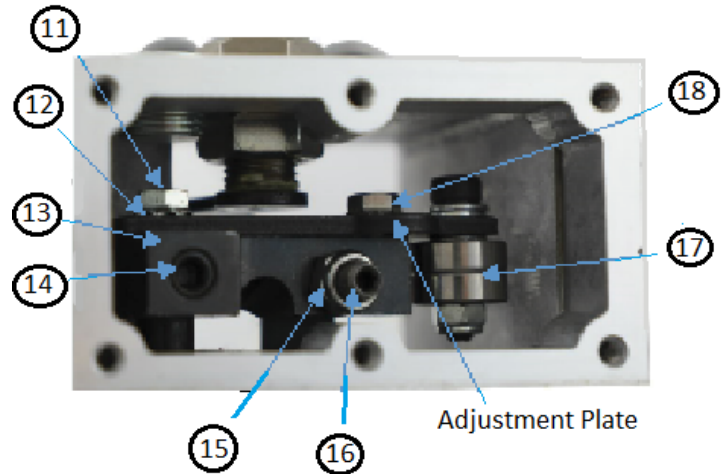



FIGURE 8 ACTUATOR ADJUSTMENT PLATE

15. While holding this position, torque the operating lever assembly shaft screw, (11) and screw (18) to 4-6 N·m (35-53 in-lb).
16. Inspect the assembly to ensure all screws are tight and the fuel rack moves smoothly without any binding.
17. Push in the fuel rack manually to the full fuel position and rotate the fuel shut off lever to the minimum fuel position to confirm the shut off lever contacts the metal plate on the fuel rack connector assembly and forces the fuel rack to minimum position.
18. The operating lever has a maximum fuel adjustment set screw (16) which can be used to restrict the fuel rack travel. Set the fuel adjustment screw and torque the locknut, Figure 8 (15), on the fuel adjustment screw to 5-6 N m (44-53 inlb).

 Setting high fuel levels may cause the maximum fuel adjusting screw to hit the top cover, which can change the minimum fuel position. When setting fuel levels above 17 mm, ensure the adjusting screw does not contact the top cover at minimum level.

19. Install the top cover and O-ring seal. When installed, the cover must not hit the internal operating lever or the maximum fuel adjustment screw.
20. Apply Loctite 222 to the six cover screws. Torque the cover screws to 2-3 N·m (18-27 in-lb) Check for any oil leaks.
21. Lock-wire the lower screws for tamper resistance.

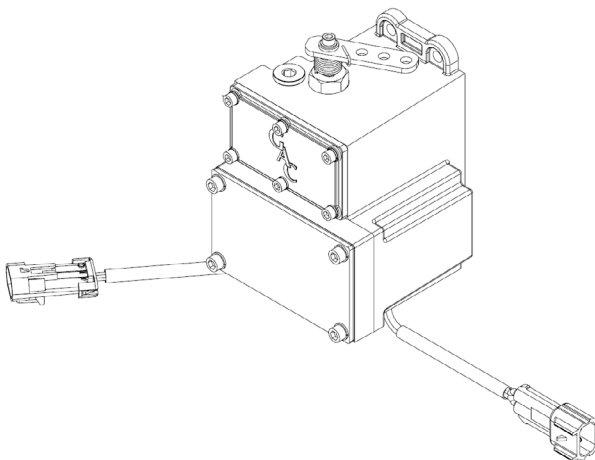

FIGURE 9 ADD175 ACTUATOR



FIGURE 10 ACTUATOR INSTALLED

5 INSTALL 2 K-TYPE THERMOCOUPLES

The STE101 kit includes a Type K Thermocouple exhaust gas temperature sensor, with mating connector.

By installing industrial rated Type K type thermocouples in the exhaust pipe of each engines bank the GAC DDM101 can measure and track two exhaust temperatures. The thermocouple adjustments on the DDM101 (THERMOCOUPLE 1 and THERMOCOUPLE 2) are calibrated at the factory to receive equal input signals from the thermocouples. If a difference in either bank's exhaust temperature is measured by the DDM101, a control loop will readjust the fuel balance automatically to minimize the difference.

Thermocouples must be installed in the center of each exhaust. The following describes the installation and troubleshooting of these sensors.

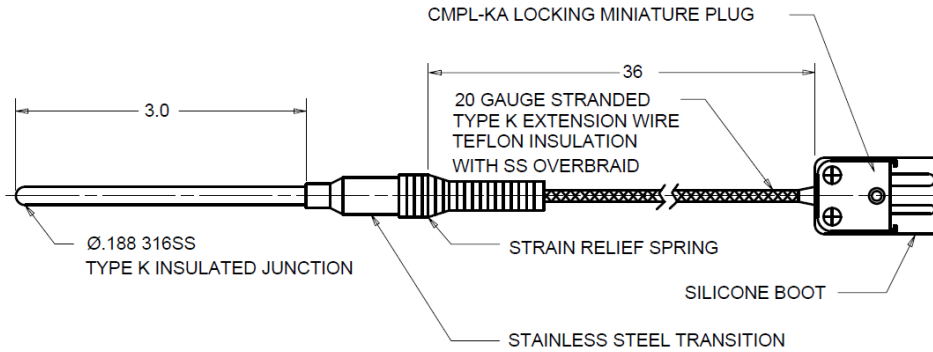

FIGURE 11 TYPE K THERMOCOUPLE



FIGURE 12 GAC STE101 KIT

- Type K Thermocouple with 1200°F (650°C)
- Mating connector
- Locking miniature Jack
- Silicone Rubber Boot
- 1/4" NPT Male Compression Fitting
- Weld-in Bung

NOTE: A weld-in bung included in STE101 is used in these instructions.

DETERMINE THERMOCOUPLE PLACEMENT

Thermocouples measure temperatures at their tip. The tip should be placed in the center of the exhaust stream to accurately measure the hottest point. The following uses an example of a dual exhaust outlet on a QTS30 engine. Your engine exhaust location may vary.

1. Locate the exhaust temperature probe in the engine exhaust outlet as near as possible to the point where all of the cylinders merge.
2. If the exhaust outlet is not easily accessible, place the sensor in the manifold outlet pipe.



FIGURE 13 EXHAUST CYLINDER MERGE

5 INSTALL K-TYPE THERMOCOUPLES (2) (CONTINUED)



- ◆ Use caution when installing the sensor. The sensor is easily damaged.
- ◆ Use Type-K wire and connectors only.
- ◆ Do not mix dissimilar metals.

Using the mounting hardware included in the STE101 kit, install one thermocouple in the exhaust manifold of each bank.

1. Determine placement location for the thermocouple in each exhaust using the thermocouple dimensions to determine mounting location and manufacturer's information.
 - Route the wires away from any ignition components.
 - If the cabling length must be extended you must use the same type grade thermocouple wire to prevent temperature compensation errors. The extension wire and connector wire are specific to the thermocouple type being used. Using the incorrect wiring components between control and process thermocouple can result in erroneous readings. Contact your GAC contact for details on the cabling recommendations.
 - Avoid bending the thermocouple sheath.
2. Mark weld-in bung placement.
3. Drill and weld the steel 1/4" NPT weld bung fitting (included with the STE101 kit).

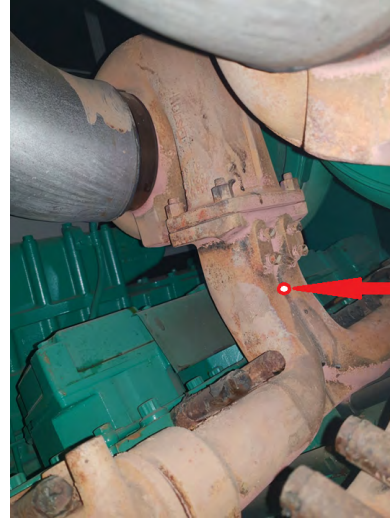

FIGURE 14 MARK WELD-IN BUNG PLACEMENT



FIGURE 15 COMPRESSION FITTING



FIGURE 16 BUNG

4. Dry fit the sensor into the bung. Ensure the tip of the probe is within the outlet exhaust flow. Use caution with the tip.
5. Apply anti-seize compound to the compression fitting threads and NPT threads.
6. Mount the sensor using the 1/4" NPT fitting.
7. Tighten compression fitting and sensor finger tight. Turn the sensor 2 full turns past finger tight.
8. Connect the sensor, ensuring the connector protection boot is in place.

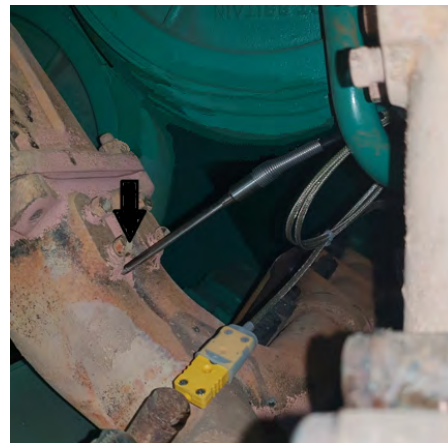



FIGURE 17 COMPRESSION FITTING WITH SENSOR IN BUNG

6 INSTALL DDM101 AND ESD5XXX CONTROLLER

The DDM101 drives the two ADD175F feedback-equipped electric actuators equally so both banks receive the same delivered fuel quantity. The DDM101 connects to the ESD51111 (ESD5221 with overspeed) electronic governing controller to control the two ADD175F position feedback actuators. Determine the location for the DDM101 and the ESD5XXX, taking into account the following:

1. Central location reachable by all wiring, available length of cabling required based on the dimensions for the DDM101 and ESD5XXX in the following figures.
2. Not directly receiving heat from the engine.

 An overspeed shutdown device, independent of the governor system, must be used to prevent loss of engine control which may cause personal injury or equipment damage. Do not rely exclusively on the governor system electric actuator to prevent overspeed. A secondary shutoff device, such as a fuel solenoid must be used.

DDM101 DIMENSIONS

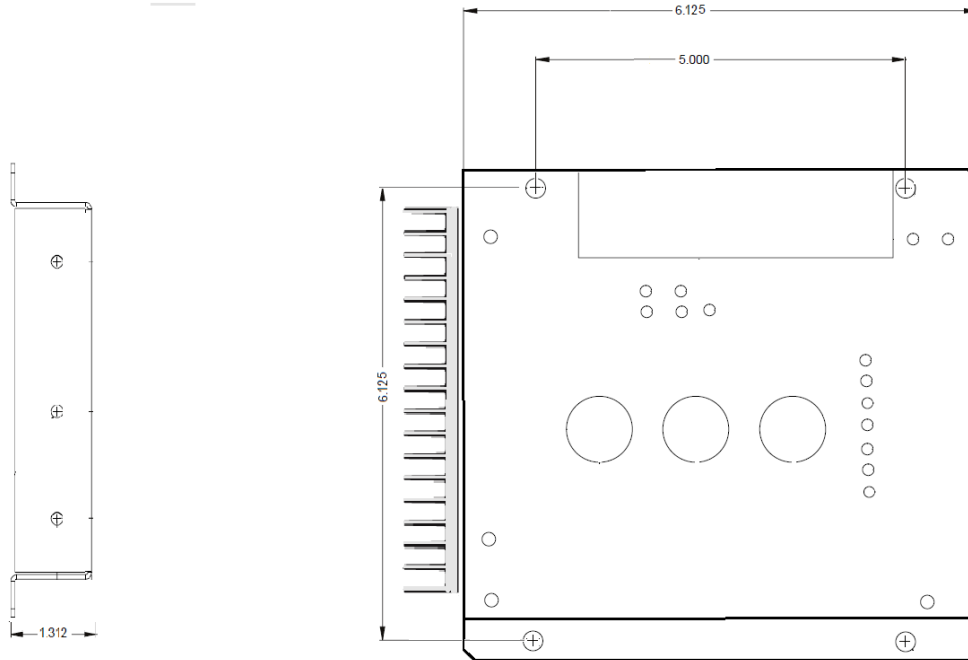

FIGURE 18 DDM101 DIMENSIONS

ESD5111/5221 DIMENSIONS

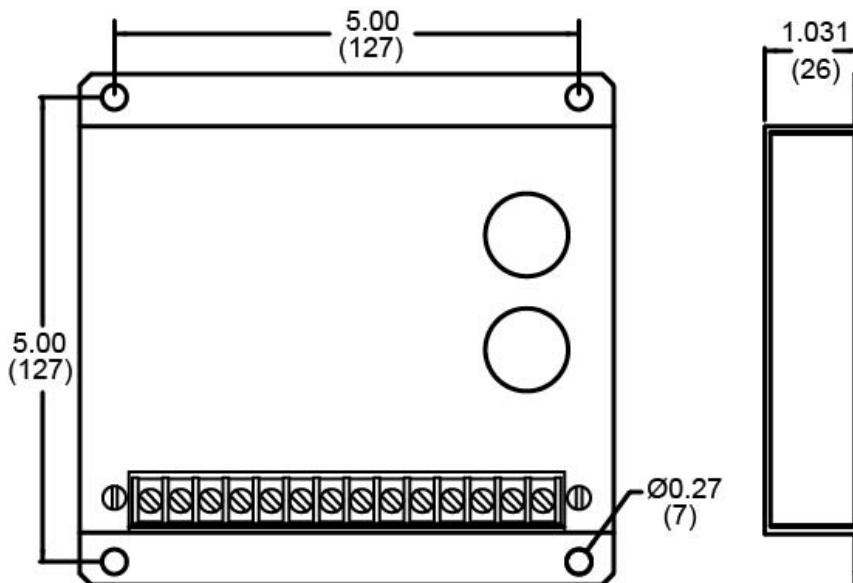

FIGURE 19 ESD5111/221 DIMENSIONS

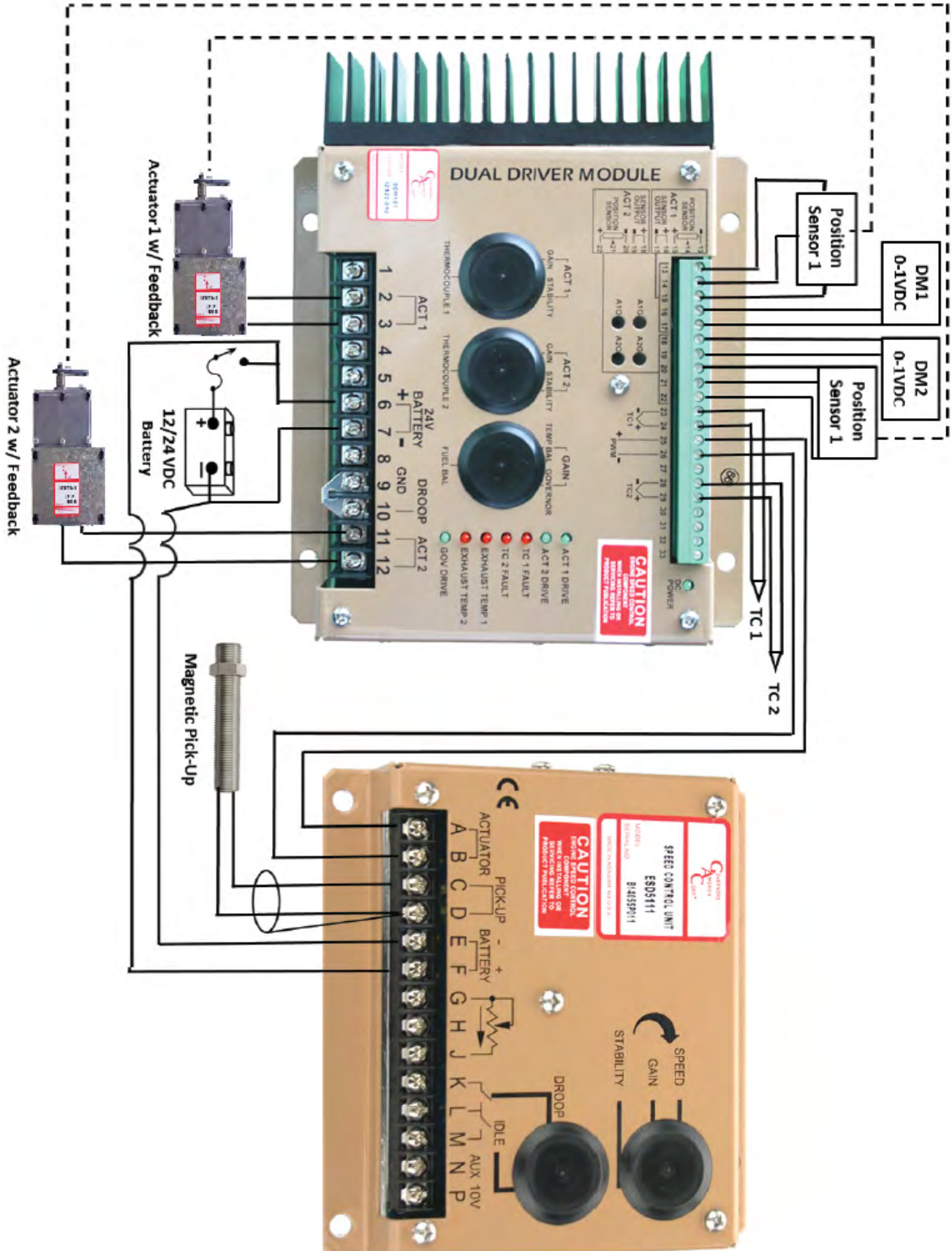

FIGURE 21 ESD5XXX TO DDM101 WIRING

CONNECTING MAGNETIC SPEED PICKUP HARNESSES

Install the magnetic speed pickup harnesses. GAC recommends using GAC CH1204, a 10', Military Connector, Shielded, MSP677/678. Connect to the ESD5111 at the C and D connectors.

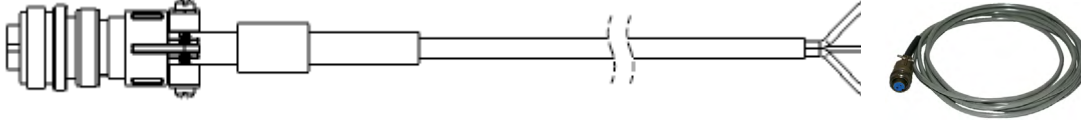
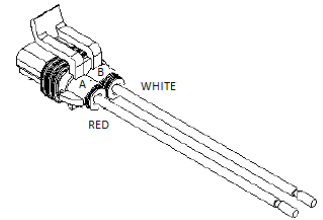

FIGURE 22 MAGNETIC SPEED PICKUP HARNESS

CONNECTING ADD175 ACTUATORS TO THE DDM101/ESD5111

The 175 Series Integral Electric Actuator is prewired for 12 or 24VDC operation. Use a GAC CH1215 cable harness or make a cable harness to connect the actuator to the speed control unit using . Recommended wire size for the ADD175F is 16 AWG.



NOTE

Do not use the ADD175 Series actuator on a 32-volt system. Contact your GAC representative for assistance.

1. Before wiring the actuators to the DDM101, determine if droop will be used.
2. Depending on the use of Droop, wire as noted in the following sections, connecting each actuator to the DDM101 using a GAC CH1215 harness.

WITHOUT DROOP

If droop is not required:

1. Connect the actuators directly to the DDM101.
2. Install a jumper between Terminals 9 and 10 on the DDM101.

WITH DROOP

If droop is required, determine which actuator should be connected for droop based on usage.

DROOP TO ACTUATOR 1

If your application requires droop, then the current in Actuator 1 is best suited for the droop signal.

1. Disconnect Terminal 26 on the DDM101 from Terminal B on the ESD.
2. Connect Terminal 3 [the minus (-) of Actuator 1 on the DDM101] to Terminal B on the ESD.
3. Connect Terminal 3 on the DDM101 to Terminal E on the ESD.
4. Droop is adjusted, proportional to the current in Actuator 1, on the ESD.

DROOP TO ACTUATOR 2

If the application requires droop be proportional to Actuator 2:

1. Remove the jumper from terminals 9 and 10
2. Disconnect Terminal 26 on the DDM101 from Terminal B on the ESD if applicable.
3. Connect Terminal 10 on the DDM101 to Terminal B on the ESD.
4. Connect Terminal 9 of the DM101 to Terminal E on the ESD.

8 ADDITIONAL WIRING (CONTINUED)

CONNECT ACTUATOR FEEDBACK SENSOR TO DDM101

Using the Feedback Sensor Mating Harnesses (CH1243) connect the ADD175F Actuators to the DDM101.

Signal	Feedback Sensor	Harness	DDM101	
			ACT1	ACT2
+5V	A - Green	A - Red	15 (+)	22 (+)
GND	B - Brown	B - Black	13 (-)	20 (-)
Out	C - White	C - White	14 (∠)	21 (∠)

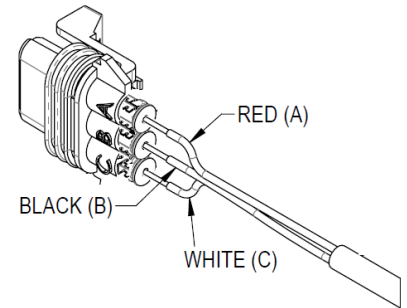

FEEDBACK SENSOR OUTPUT

The ADD175 feedback sensor provides linear position feedback. The following is the average linear position feedback sensor output.

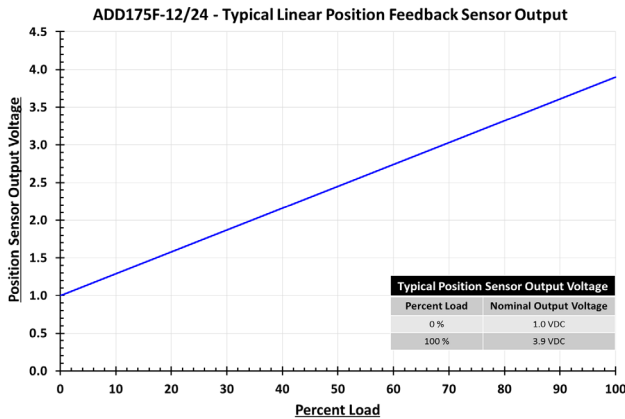

FIGURE 25 ADD175F TYPICAL PERCENT TRAVEL POSITION FEEDBACK SENSOR OUTPUT

9 CONNECTING ESD5111 TO DDM101

The ESD5111 uses the same actuator voltage driver type with Pulse width modulation (PWM) output as the DDM101. In normal actuator usage with a GAC ESD, one side of the actuator is typically at or near ground level voltage.

1. Connect Terminal B on the ESD, (the low side of the actuator drive) to Terminal 26 on the DDM101.
2. Connect Terminal A on the ESD, (the high side output of the actuator), to Terminal 25 on the DDM101.
3. Case ground (right or left corner screw) should be connected to battery minus (Terminal 7) with a separate cable for the best EMC ratings.

The ESD5111 comes with the Lead circuit already enabled via a jumper across posts E7 and E6.

10 ADJUST SYSTEM SETTINGS BEFORE STARTING ENGINE

The following ESD settings are suggested to start. Each engine will vary for its final tuning needs.

ESD5111 SETTINGS

The speed control unit governed speed setting is factory set at approximately engine idle speed of 1000 Hz., Speed sensor information or 600RPM.

Frequency range is selected according to the frequency of the signal sent by the magnetic speed pickup at desired operating speed. The potentiometer setting is dependent on the frequency. Review the following conversion table for details.

Conversion Formulas

$$\text{Hertz}_{\text{MAG PICKUP}} = \frac{(\text{RPM} \times \# \text{Teeth})}{60 \text{sec}} \quad \text{RPM} = \frac{(\text{Hertz}_{\text{MAG PICKUP}} \times 60 \text{sec})}{\# \text{Teeth}}$$

SPEED FREQUENCY RANGE	POTENTIOMETER VALUE
900 Hz	1 K
2400 Hz	5 K
3000 Hz	10 K
3500 Hz	25 K
3700 Hz	50 K

1. On the ESD5111, set the potentiometers to the middle settings for middle settings Gain Stability, and Speed to start.
2. Rotate the SPEED adjustment counter-clockwise until the potentiometer clicks. Then turn clockwise 5 turns. This is a 25-turn pot so it will take time to turn.
3. Select the desired speed range and corresponding potentiometer value. If the exact range cannot be found, select the next higher range potentiometer.

DDM101 SETTINGS

Restore factory settings on the DDM101.

SETTING	RANGE	DEFAULT
ACT1	Gain	270° Turn
	Stability	270° Turn
	Thermocouple	270° Turn
ACT2	Gain	270° Turn
	Stability	270° Turn
	Thermocouple	270° Turn
GAIN	Temp Balance	270° Turn
	Governor	270° Turn
	Fuel Balance	25 Turn
		12 Turns CW

11 START THE ENGINE

The speed control unit governed speed setting is factory set at approximately engine idle speed (1000 Hz., Speed sensor signal, or 600 RPM).

Crank the engine with DC power applied to the governor system. The actuator will energize to the maximum fuel position until the engine starts. The governor system will control the engine at low or near idle speed. If the engine is unstable after starting, readjust for stability as detailed in the [Tune the Engine](#) section of this manual.

If the engine does not start, review the [Troubleshooting](#) section in this manual. Call your GAC representative if you continue to have problems.

12 TUNE THE ENGINE

Once the engine is running at operating speed with no load, performance adjustments can be made. For full details on the ESD5XXX and DDM101 capabilities see the GAC website.

SPEED, GAIN, and STABILITY

With the engine running at rated speed, no load, adjust the gain, and stability (PID) in the ESD5111 for optimum performance.

On the ESD5111:

1. At rated speed with no load, rotate the GAIN adjustment clockwise until instability develops.
2. Gradually move the adjustment counterclockwise until stability returns.
3. Move the adjustment one division further counterclockwise to ensure stable performance (270° potentiometer).
4. If instability persists, further adjust Stability.

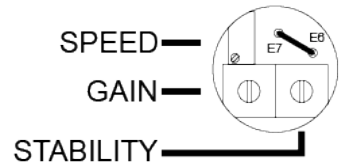

FIGURE 26 P I D

NOTE The SPEED adjustment is a 25-turn potentiometer.

ADJUSTING GAIN

With the engine running at rated speed, adjust the gain, and stability (PID) at the ESD5111 or the DDM101 for optimum performance.

- For best performance, the ESD5111 GAIN adjustment should be set between 40-60% of range.
- If the ESD5111 GAIN adjustment is below 25%, the DDM101's GOVERNOR GAIN adjustment should also be rotated counter-clockwise to a lower setting. Readjust the PID settings for optimum transient performance.
- Adjusting the DDM101 can also be accomplished by analyzing the ESD PWM voltage input to Terminals 25 and 26 on the DDM101. The desirable voltage reading between Terminals 25 and 26 should measure 7 VDC at no load and 14 VDC at full load.
- If the measured voltage is lower than the desired range, the DDM101's GAIN adjustment is set too high and should be rotated counter-clockwise to a lower setting.
- The voltage across Terminals 25 and 26 on the DDM101 should increase.

ADJUSTING ACTUATOR STABILITY

Each actuator has its own actuator STABILITY [ACT 1 and ACT 2] adjustment to optimize system stability. At the DDM101:

1. Adjust both ACT 1 and ACT 2 STABILITY adjustments as high as possible without engine or actuator instability.
2. Adjust Actuator 1 first by rotating the ACT 1 STABILITY adjustment counter-clockwise until instability in the engine develops. Gradually move the adjustment CW until stability returns.
3. Move the adjustment 1/8 of a turn clockwise to ensure stable performance.
4. Next, adjust Actuator 2 via the ACT 2 STABILITY adjustment following the above described method.
5. Poke or disturb the actuator to try to induce instability. Adjust the GAIN and STABILITY for best response of the actuator.

ADD IDLE SPEED

At the ESD5111, after the governor speed setting had been adjusted, place the optional external selector switch in the IDLE position. The idle speed set point is increased by the clockwise rotation of the IDLE adjustment control. When the engine is at idle speed, the speed control unit applies droop to the governor system to ensure stable operation.

ADD DROOP

Droop is used to ensure when two engines are used in parallel the engine speed will decrease as engine load increases. The percentage of droop is based on the actuator current change from no engine load to full load. Droop must have been previously wired. See DROOP for more information. At the ESD5111:

1. Place the optional external selector switch in the DROOP position. DROOP is increased by clockwise rotation of the DROOP adjustment control.
2. After the droop level has been adjusted, the rated engine speed setting may need to be reset. Check the engines speed and adjust speed setting accordingly.
3. Though a wide range of droop is available with the internal control, droop level requirements of 10% are unusual. If droop levels experienced are higher or lower than those required, contact GAC for assistance.

ADD FUEL BALANCE

The FUEL BALANCE adjustment allows for equalization of the fuel being delivered by each actuator. At the DDM101, with the engine running at no load, measure the DC voltage output of the feedback sensors from each actuator.

- Voltage measurement for Actuator 1 is taken across Terminals 13 and 14.
- Voltage measurement for Actuator 2 is taken across Terminals 20 and 21.
- Both voltage measurements should have an operational range of 1 to 4 VDC.
- If the voltage readings are not equal, adjust the FUEL BALANCE potentiometer on the DDM101 until the voltage readings are equalized and the exhaust temperatures are balanced.

12 TUNE THE ENGINE (CONTINUED)

ADD POSITION LOOP GAIN

Each actuator driver circuit has its own actuator GAIN [ACT 1 and ACT 2] adjustment on the DDM101 to optimize the feedback control loop response. At the DDM101:

1. Adjust ACT 1 and ACT 2 as high as possible without developing engine or actuator instability.
 - a. Adjust Actuator 1 first by rotating the ACT 1 GAIN potentiometer clockwise until instability in the engine develops.
 - b. Gradually move the adjustment counter-clockwise until stability returns.
 - c. Move the adjustment 1/8 of a turn counter-clockwise to ensure stable performance.
 - d. Adjust the ACT 2 GAIN potentiometer following the above described method.
 - e. Poke or disturb the actuator to try to induce instability.
 - f. Adjust the GAIN and STABILITY adjustments for best response from the actuators.
2. The SPEED and GAIN adjustment on the ESD and the GAIN [ACT 1 and ACT 2] adjustments on the DDM101 can have some interaction. It is possible to turn one up and the other down and get similar results.
3. The GAIN adjustments on the DDM101 must not be turned to low or speed control performance may suffer. A mid-range setting or higher for all of the GAIN adjustments is recommended.

MONITOR RACK POSITION

To monitor rack position, using a multimeter, apply voltage to the DDM101 but before starting the engine, measure the voltage at Terminals 16(+) & 17(-).

- Voltage should be adjusted to zero volts at the Actuator 1 Offset (A1 O) for Actuator 1 (closed position) and Terminals 18(+) & 19(-) at the Actuator 2 Offset (A2 O).
- At maximum position the voltage at the terminals 16-19 should be 1 Volt and can be adjusted using Actuator 1 Gain (A1 G) and Actuator 2 Gain (A2 G) respectively.
- To manually open the actuator, remove the wire from Terminal A on the ESD and connect the wire to Terminal F on the ESD. Adjust A1 G and A2 G for 1 Volt output at Terminal 16 and Terminal 18. Reconnect the wire back to Terminal A on the ESD.

MONITOR EXHAUST PIPE TEMPERATURE DIFFERENCE

The DDM101 requires the use of exhaust temperature thermocouples to balance the load precisely with the dynamic balancing function. The thermocouple adjustments (THERMOCOUPLE 1 & THERMOCOUPLE 2) are calibrated at the factory to receive equal input signals from the thermocouples.

1. If a difference in either bank's exhaust temperature is measured by the DDM101, the control loop will readjust the fuel balance automatically to minimize the difference.
2. If a measured difference is still found, manually reduce the unbalance and increase the temp control loop authority by turning TEMP. BAL GAIN adjustment clockwise.
3. If at any time, one or both of the thermocouple signals are lost (open circuit detected) the TC 1 or TC 2 fault LED will light and the balancing function will shut off.
4. Adjusting the cooler banks THERMOCOUPLE adjustment CW will also equalize the exhaust temperature.



Do not alter the factory settings of THERMOCOUPLE 1 or THERMOCOUPLE 2 adjustments unless a significant unbalance exists. If a balance does occur, first try to correct the issue using the standard mechanical and electronic balancing methods described above.

If a problem persists, determine which exhaust channel is higher in temperature and adjust the bank's THERMOCOUPLE adjustment counter-clockwise to equalize the exhaust temperature.

The following LEDs on the DDM101 signal the thermocouple functions.

LED	FUNCTION
ACT 1	Actuator drive circuit 1 is receiving a drive signal from the control.
ACT 2	Actuator drive circuit 2 is receiving a drive signal from the control.
TC 1	FAULT Thermocouple 1 has a fault or open circuit.
TC 2	FAULT Thermocouple 2 has a fault or open circuit.
EXHAUST TEMP 1	Unbalances in exhaust temperatures; control is actively trimming fuel to actuator 1 to rebalance the system
EXHAUST TEMP 2	Unbalances in exhaust temperatures; control is actively trimming fuel to actuator 2 to rebalance the system.
GOV DRIVE	Drive signal from external governor is being removed to open up the throttle.

GENERAL ISSUE	POSSIBLE SOLUTION	
Insufficient magnetic speed signal	<ol style="list-style-type: none"> 1. A strong magnetic speed sensor signal eliminates missed or extra pulses. The speed control unit will govern well with 1.0 V AC speed sensor signal. A speed sensor signal of 3 volts VAC or greater at governed speed is recommended. 2. Measure signal at Terminals C and D. 3. To raise the amplitude of the speed sensor signal, reduce the gap between the speed sensor tip and the engine ring gear. The gap should not be < 0.025 in (0.64 mm). When the engine is stopped, back the speed sensor out by 1/4 turn after touching the ring gear tooth to achieve a satisfactory air gap. 	
Thermocouples not responding	<p>If one or both of the thermocouple signals are lost (open circuit detected) the TC 1 or TC 2 fault LED will light and the balancing function will shut off. Do not alter the thermocouple factory settings.</p> <ul style="list-style-type: none"> • Adjust the TEMP. BAL GAIN potentiometer on the DDM101. • If a problem persists: • Determine which exhaust channel is higher in temperature and adjust the bank's THERMOCOUPLE adjustment counter-clockwise to equalize the exhaust temperature. • Adjust the cooler banks THERMOCOUPLE adjustment clockwise to equalize the exhaust temperature. • Examine protection tubes for excessive corrosion, wear, oxidation and physical damage. Protection tubes exhibiting damage and/or excessive corrosion should be replaced. Wiring should be examined for damaged insulation and tight connection points. 	
System inoperative	<ul style="list-style-type: none"> • Positive (+) and negative (-) refer to meter polarity. Should normal values be indicated during troubleshooting steps, and then the fault may be with the actuator or the wiring to the actuator. • Tests are performed with battery power on and the engine off, except where noted. • See your GAC representative for additional help for inoperative system issues after reading this manual. 	
System inoperative	F(+) & E(-) Battery Supply Voltage (12 or 24 V DC)	<ul style="list-style-type: none"> • DC battery power not connected. Check for blown fuse. • Low battery voltage. • Wiring error.
System inoperative	C(+) & D(-) 1.0 V AC minimum while cranking	<ul style="list-style-type: none"> • Gap between speed sensor and gear teeth too great. Check Gap. • Improper or defective wiring to the speed sensor. Resistance between D and C should be 160 to 1200 ohms. See specific mag pickup data for resistance. • Defective speed sensor.
System inoperative	P(+) & G(-) 10 V DC, Internal Supply	Short on Terminal P. Defective speed control unit.
System inoperative	F(+) & A(-) 1.0 - 2.0 V DC while cranking	<ul style="list-style-type: none"> • SPEED parameter set too low. • Short/open in actuator wiring. • This may be a defective speed control. See your GAC representative for more information.
Instability: The engine jitters at 3Hz or faster.	Fast Periodic	<ul style="list-style-type: none"> • Turn off other electrical equipment that may be causing interference. Readjust the GAIN and STABILITY for optimum control. • Remove the E6 to E7 jumper to reduces sensitivity to high frequencies. • If system is still unstable, remove the E1 to E2 jumper and readjust GAIN and STABILITY.
Instability: Irregular speed below 3Hz	Slow Periodic	<ul style="list-style-type: none"> • Readjust the GAIN and STABILITY. • Set DIP switches 1 and 2 to "ON" in the following order: First SW1, Second SW2. • Check fuel system linkage during engine operation for: <ul style="list-style-type: none"> • binding • high friction • poor linkage • Adjust the DEAD TIME COMPENSATION on the DDM101 by adding a capacitor from posts E2 to E3 (negative on E2). Start with 10 mfd.

GENERAL ISSUE	POSSIBLE SOLUTION	
Instability: erratic engine behavior	Non-Periodic	<p>Increasing the GAIN should reduce the instability but not totally correct it.</p> <p>If this is the case, there is most likely a problem with the engine itself. Check for:</p> <ul style="list-style-type: none"> • engine mis-firings • an erratic fuel system • load changes on the generator set voltage regulator. <p>If throttle is slightly erratic, but performance is fast, then remove the jumper from E6 to E7.</p>
Unsatisfactory performance: engine overspeed	Do Not Crank. Apply DC power to the governor system.	After the actuator goes to full fuel, disconnect the speed sensor at Terminals C and D. If the actuator is still at full fuel-speed then the speed control unit is defective.
Unsatisfactory performance	<p>Manually hold the engine at the desired running speed.</p> <p>Measure DC voltage between Terminals A(-) & F(+) on the speed control unit.</p>	<p>If the voltage reading is 1.0 to 2.0 V DC:</p> <ul style="list-style-type: none"> • SPEED adjustment is set above desired speed • Defective speed control unit • If voltage reading is above 2.0 V DC then check for: <ul style="list-style-type: none"> • actuator binding • linkage binding • Set point of overspeed shutdown device set too low. • If the voltage reading is below 1.0 V DC most probably a defective speed control unit. Call GAC.
Overspeed shuts down engine after running speed reached	<ul style="list-style-type: none"> • Speed adjustment set too high. • OVERSPEED set to close to running speed. • Actuator or linkage binding. • Speed control unit defective. 	
Actuator does not energize fully	Measure the voltage at the battery while cranking.	If voltage is less than 7 V for a 12 V system, or 14 V for a 24 V system, check or replace the battery.
Overspeed shuts down engine	Momentarily connect Terminals A and F.	<p>The actuator should move to the full fuel position.</p> <ul style="list-style-type: none"> • Actuator or battery wiring in error • Actuator or linkage binding • Defective actuator • Fuse opens. Check for short in actuator or harness.
Engine remains below desired governed speed	Measure the actuator output, Terminals A & B, while running under governor control.	<p>If voltage measurement is within 2 VDC of the battery supply voltage level, then fuel control is restricted from reaching full fuel position, possibly due to mechanical governor, carburetor spring, or linkage interference.</p> <p>SPEED parameter set too low.</p>